



# EXW3 ACB

## PRODUCT CATALOG



HUANYU HIGH TECH CO.,LTD.  
HUYUELECTRIC.COM

EXPLORE

# EXW3 Air Circuit Breaker

## Functions and Features

### Structure description

#### Circuit breaker description

The circuit breaker offers compact structure and modular feature. The contact system is enclosed between two insulating bottom plates with a separate structure. Each phase contact is separated into independent small cells. The intelligent controller, operating mechanism, manual operator and motor operator are arranged in the front to form their own independent unit. In case of any fault, the unit can be removed and replaced as a whole (see Figure 2 and Figure 3).

Figure 1. Operating instruction diagram of EXW3 series air circuit breaker

- 1 Cassette
- 2 Cover
- 3 Fault reset button
- 4 Opening button
- 5 ON/OFF indicator
- 6 Intelligent controller
- 7 Operation padlock
- 8 Racking handle
- 9 Secondary wiring terminal
- 10 Energy-storage handle
- 11 Closing button
- 12 Energy-storage/Release indicator
- 13 Nameplate
- 14 3-position indication
- 15 Racking handle entry
- 16 3-position lock

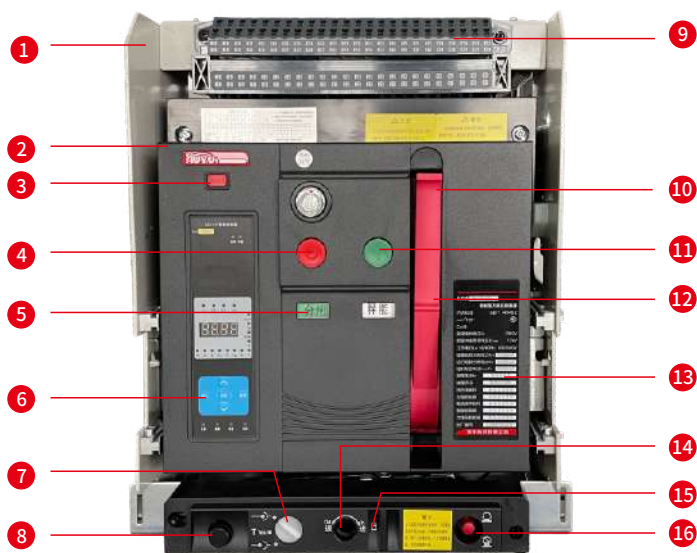

# EXW3 Air Circuit Breaker

## Functions and Features

Figure 2. Internal diagram of EXW3 series air circuit breaker

- ① Secondary wiring terminal (basic device)
- ② Shunt release
- ③ Closed electromagnet
- ④ Auxiliary contact
- ⑤ Motor operating mechanism
- ⑥ Operating mechanism

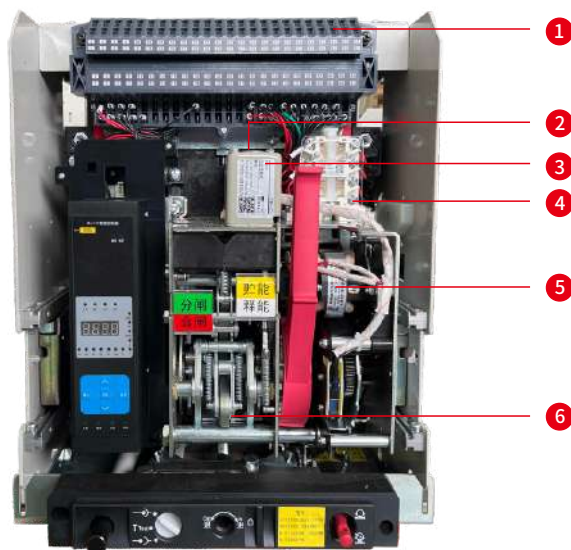
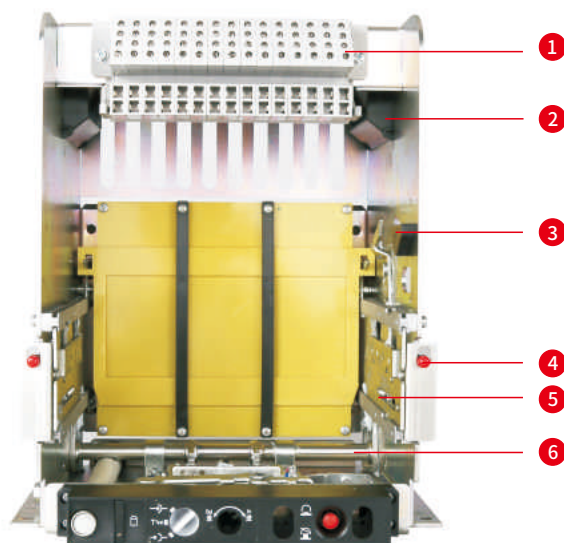

Figure 3. EXW3 series air circuit breaker cassette

- ① Secondary wiring terminal(cassette part)
- ② Handle
- ③ Adjusting support
- ④ Rail lock
- ⑤ Guide
- ⑥ Transmission shaft



# EXW3 Air Circuit Breaker

## Functions and Features

---

### Product description



### Features

- 7 Frame Size: 1600、2000、2500、3200、4000、6300AF
- Rated current  $I_n$ (A): 400-6300
- Rated voltage AC  $U_e$  (V): 400/415、660/690
- Poles: 3 & 4
- 3 type of intelligent controllers

### Normal operating conditions

- 1.Applicable temperature:
  - Suitable for use at  $-5^{\circ}\text{C}$  to  $+40^{\circ}\text{C}$ ;
  - Also for use at  $-40^{\circ}\text{C}$  to  $+70^{\circ}\text{C}$  (Mic1.0 standard type), and  $-25^{\circ}\text{C}$  to  $+70^{\circ}\text{C}$  (Mic2.0 multi-function type, and Mic5.0 intelligent type)
- 2.Altitude:  $\leq 2,000\text{m}$  at the mounting site;
- 3.Atmospheric conditions:
  - Air relative humidity:  $\leq 50\%$  at the maximum temperature of  $+40^{\circ}\text{C}$ , and a higher relative humidity is allowed when at a lower temperature;
  - For example, at  $20^{\circ}\text{C}$ , the humidity is 90%, and special measures should be taken for occasional condensation due to temperature change;
- 4.Pollution level: Level 3;
- 5.Mounting category:
  - IV for circuit breaker' s main circuit, under-voltage release coil, and power transformer' s primary coil;
  - III for other auxiliary circuits and control circuits;
- 6.Utilization category: B

### Classifications

- 1.By mounting method: Fixed type and withdrawable type
- 2.By operating mode: Motor operating and manual operating (for maintenance and repair)
- 3.By the number of poles: 3P and 4P
- 4.By release type: Intelligent controller, under-voltage instantaneous (or time delay) release, and shunt release
- 5.By intelligent over-current controller function: Mic5.0 (intelligent type), Mic2.0 (multi-function type); Mic1.0 (standard type).

# EXW3 Air Circuit Breaker

## Functions and Features

### Product selection

<b>EXW3</b>	<b>N</b>	<b>2000</b>	<b>D</b>	<b>3</b>	<b>2000A</b>
Model number	Breaking capacity	Frame size (A)	Installation	Number of poles	Rated current
EXW3	N: (basic type)	1600 2000 2500 3200 4000 6300	D: draw-out F: fixed	3: 3P 4: 4P	630A ..... 6300A
<input type="checkbox"/>	<b>M1</b>	<input type="checkbox"/>	<input type="checkbox"/>	<input type="checkbox"/>	<input type="checkbox"/>
Control voltage	Controller type	Mounting method	Auxiliary switch	Door +frame sealing ring	Inter-phase partition
AC230V AC400V DC220V DC110V	M1: Mic1.0 M2: Mic2.0 M5: Mic5.0	V:Vertical	4NOs/4NCs 6NOs/6NCs	Draw-out fixed	2pcs(3P) 3pcs(4P)
<input type="checkbox"/>	<input type="checkbox"/>	<input type="checkbox"/>	<input type="checkbox"/>	<input type="checkbox"/>	<input type="checkbox"/>
Under-voltage release	Key lock	Mechanic interlocking	Dual-power controller	External transformer	Other
AC230V AC400V	One lock, one key Two locks and one key Three locks and two keys	Lever interlock Steel cable interlock	Dual-power controller Three-power controller Bus controller	N-phase current transformer Ground current transformer Leakage current transformer	Optional functions

## Technical data and performance

### Technical data

Frame size(Inm)		EXW3-1600	EXW3-2000	EXW3-2500	EXW3-3200	EXW3-4000	EXW3-6300
		N	N	N	N	N	N
Rated operating In(A)		200、400 630、800 1000、1250、1600	630、800、1000 1250、1600、2000	2500	2000、2500、3200	4000	4000、5000、6300
Neutral pole rated current In(A)		100%In	100%In	100%In	100%In	100%In	50%In
Rated operated voltage Ue(V)		AC400/415/440/690					
Rated frequency		50/60Hz					
Number of poles		3P/4P					
Rated impulse withstand voltage Uimp(kV)		AC12					
Rated insulation Voltage Ui(V)		AC1000					
Power frequency withstand voltage(V)		AC3500					
Rated short-circuit breaking capacity Icu (kA)	AC400V/415V	50	85	85	85	85	120
	AC440V/690V	35	50	50	65	65	85
Operating short-circuit breaking capacity Ics(kA)	AC400V/415V	42	65	65	70	70	100
	AC440V/690V	35	50	50	65	65	85
Rated short-time withstand current Icw/1s (kA)	AC400V/415V	42	65	65	70	70	100
	AC440V/690V	35	50	50	65	65	85
Rated short-circuit making capacity Icm (kA)	AC400V/415V	110	187	187	187	187	264
	AC440V/690V	73.5	110	110	143	143	187
Utilization category		B					
Breaking time		≤30 ms					
Marking time		≤70ms					
Electrical life(times) ≤2000 1time/3min >2000 1time/6min	400V	5000	4500	4000	4000	3000	2000
	Without maintenance	10000	10000	10000	8000	8000	5000
Mechanical life(times) ≤2000 1time/3min >2000 1time/6min	With maintenance	20000	20000	20000	15000	15000	8000
	Mechanical life of drawer type (times) 1time/2min	1000	1000	1000	600	600	300
Incomming method		Incomming method					
Flashover distance(mm)		0					
Installation method		Fixed type or withdrawable type					

## Controller panel structure

Controller function		Mic1.0	Mic2.0	Mic5.0	Note
Interface display	Digital display (keypad);	■	—	—	
	LCD display (liquid crystal);	—	■	■	
Protection function	Overload long delay protection;	■	■	■	
	Overload thermal memory;	■	■	■	
	Overload pre-alarm;	□	□	■	
	Short-circuit short delay protection;	■	■	■	
	Short-circuit instantaneous protection;	■	■	■	
	Ground fault protection (differential type);	■	■	■	
	Ground fault alarm;	□	□	■	
	Neutral line protection (4P, 3P N);	■	■	■	
	Current unbalance protection;	—	■	■	
	MCR and HSISC protection;	□	□	□	
	Load monitoring;	—	□	■	
	Under/over voltage protection;	—	□	■	
	Voltage unbalance protection;	—	□	■	
	Phase sequence protection;	—	□	■	
	Under/over frequency protection;	—	□	■	
	Demand value protection (current);	—	□	■	
	Reverse power protection;	—	□	■	
	Zone selective interlocking;	—	□	□	
	Residual current protection;	□	□	□	
	Missing phase protection;	□	□	■	
Over temperature protection and alarm;	□	□	□		
Measurement function	Current measurement (phase pole, N pole);	■	■	■	
	Voltage (phase voltage, line voltage, voltage unbalance rate);	—	□	■	
	Phase sequence detection;	—	—	■	
	Frequency measurement;	—	—	■	
	Demand value measurement (current);	—	—	■	
	Demand value measurement (power);	—	—	■	
	Power measurement (active power, reactive power, apparent power);	—	—	■	
	Power factor measurement;	—	—	■	
	Energy measurement (active energy, reactive energy, apparent energy);	—	—	■	
	Harmonic measurement;	—	—	■	
Maintenance function	Thermal capacity measurement;	—	—	■	
	LED fault status indication;	■	■	■	
	Fault recording and inquiry;	■	■	■	
	Historical current peak value record;	—	■	■	
	Alarm history record inquiry;	—	■	■	
	Fault trip signal output;	■	■	■	
	Self-diagnostic function;	■	■	■	
	Analog trip test function;	■	■	■	
	Contact wear equivalent (alarm) % inquiry;	■	■	■	
	Operating times inquiry;	■	■	■	
Other	Clock function;	—	■	■	
	Controller remote reset;	□	□	□	
	Communication function: Modbus-RTU;	—	—	■	
	I/O setting function;	—	□	■	
	Password setting function;	—	■	■	
External CT function;	□	□	□		

— indicates no such function; ■ indicates standard function; □ indicates optional function.

Rated working voltage: AC230/400V 50/60Hz、DC220V/110V/24V

# EXW3 Air Circuit Breaker

## Functions and Features

### Mic1.0(standard type)

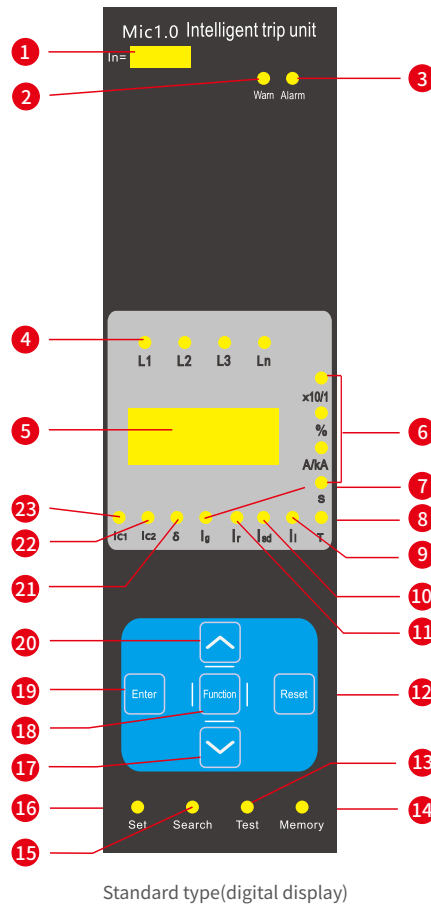

Standard type(digital display)

- |  |  |
|--|--|
| <p>1 In: Rated current</p> <p>2 Fault lamp</p> <p>3 Alarm lamp</p> <p>4 L1, L2, L3 and N indicators<br/>N phase Current<br/>A phase Current<br/>B phase Current<br/>C phase Current</p> <p>5 Digital display window--<br/>display the current value,<br/>the setting parameter,<br/>the fault current, the tripping time</p> <p>6 Parameter indicator--<br/>X10/1: the number of CB operations,<br/>% : the percentage of contact wear,<br/>A/kA : ampere/klA for current;<br/>S: time</p> <p>7 Ig: Ground fault tripping</p> <p>8 Self-diagnostic fault indicator</p> <p>9 Ii: Instantaneous tripping</p> | <p>10 Isd: short delay tripping</p> <p>11 Ir: overload long-time delay tripping</p> <p>12 Return key: back to the previous level or resetting</p> <p>13 Test: tripping indication</p> <p>14 Store indicator: Indicating that a data change has occurred</p> <p>15 "Query" key--The indicator is always lit on,<br/>allowing people to view historical fault information</p> <p>16 Setting" key--The indicator is always on,<br/>allowing people to view or modify the settings of various<br/>protection characteristic parameters</p> <p>17 -/ down page</p> <p>18 "Function" key</p> <p>19 Enter key</p> <p>20 +/- up page</p> <p>21 Indicator--Current imbalance setting and alarm indicator light</p> <p>22 Ic2 indicator--Settings for load monitoring 2 and alarm lights</p> <p>23 Ic1 indicator --Settings for load monitoring 1 and alarm lights</p> |
|--|--|

# EXW3 Air Circuit Breaker

## Functions and Features

Interface legend, indicator and button descriptions of Mic1.0 standard controllers

### Mic2.0 and Mic5.0 (standard type)

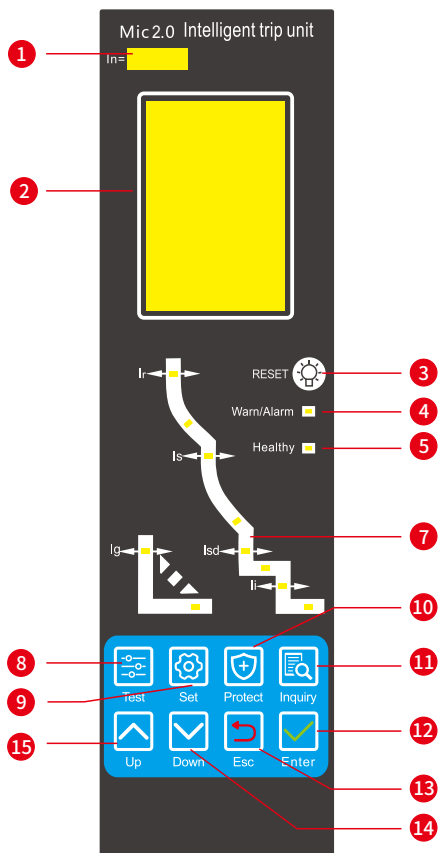

Multifunctional type (LCD display)

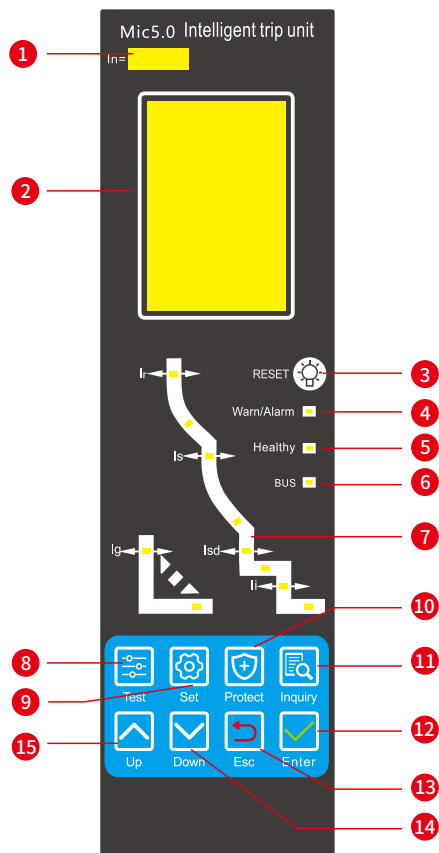

Multifunctional type (LCD display)

- 1 In: Rated current
- 2 LCD screen with three-color backlight. Green stands for normal running, yellow stands for alarming and red stands for tripping.
- 3 Reset button
- 4 Fault /Alarm lamp
- 5 Running indicator flickering in normal running
- 6 Communication indicator
- 7 Parameter indicator--  
X10/1: the number of CB operations,  
% : the percentage of contact wear,  
A/kA : ampere/kla for current;  
S: time
- 8 Test button for tripping test  
Setting button

- 9 Protection functions button
- 10 Protection functions button
- 11 Information key
- 12 Enter key
- 13 Return key;back to the previous level or resetting
- 14 -/ down page
- 15 +/ up page

Note: Due to rapid upgrade of intelligent controllers, the actual controller type shall prevail, not limited to the above-mentioned controller types.Relevant functions can be tailor-made to your requests.

# EXW3 Air Circuit Breaker

## Functions and Features

### Protection features and functions of the intelligent over-current controllers

Figure 1. Standard inverse time

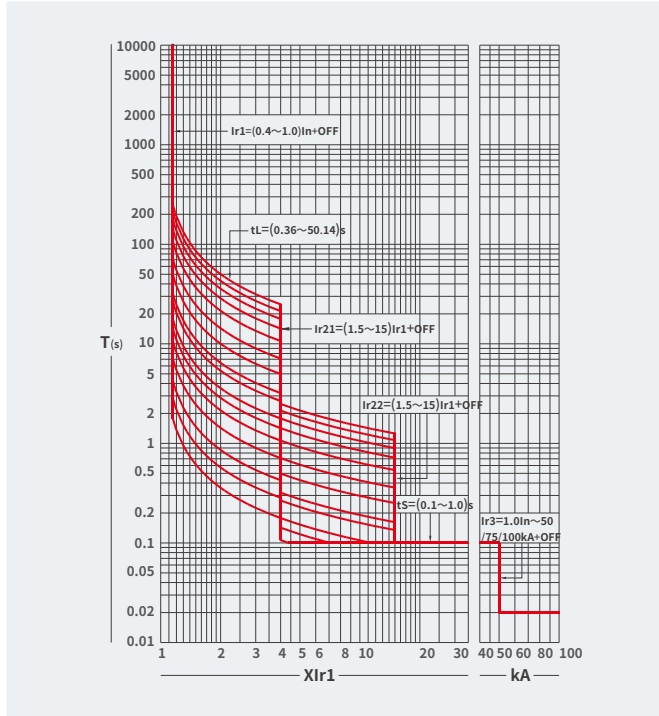

Figure 2. Grounding fault protection

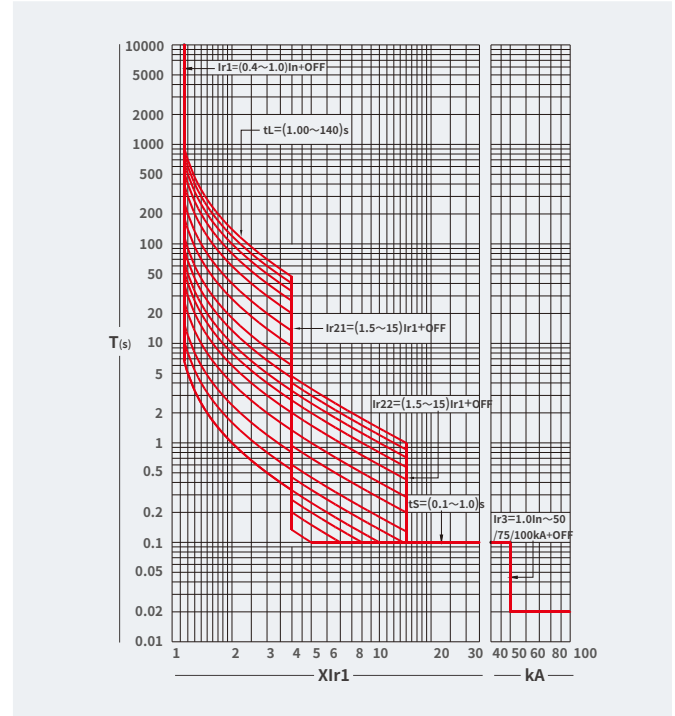

Figure 3. Extremely fast inverse time (general protection)

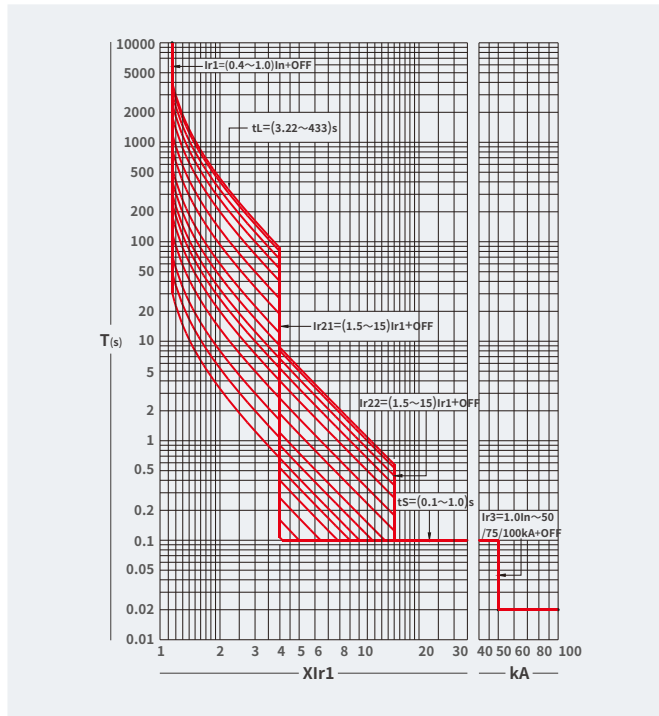
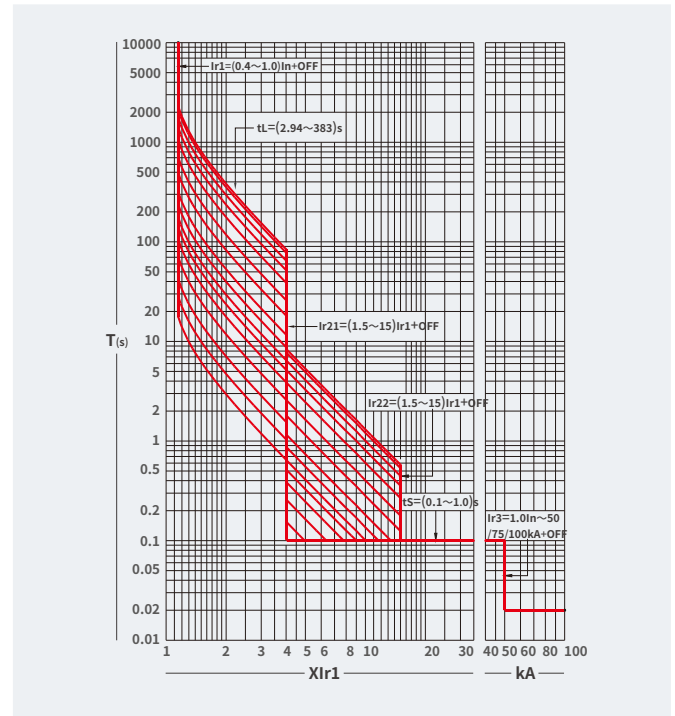

Figure 4. Extremely fast inverse time (motor protection)



# EXW3 Air Circuit Breaker

## Functions and Features

Figure 5. High-voltage fuse compatible

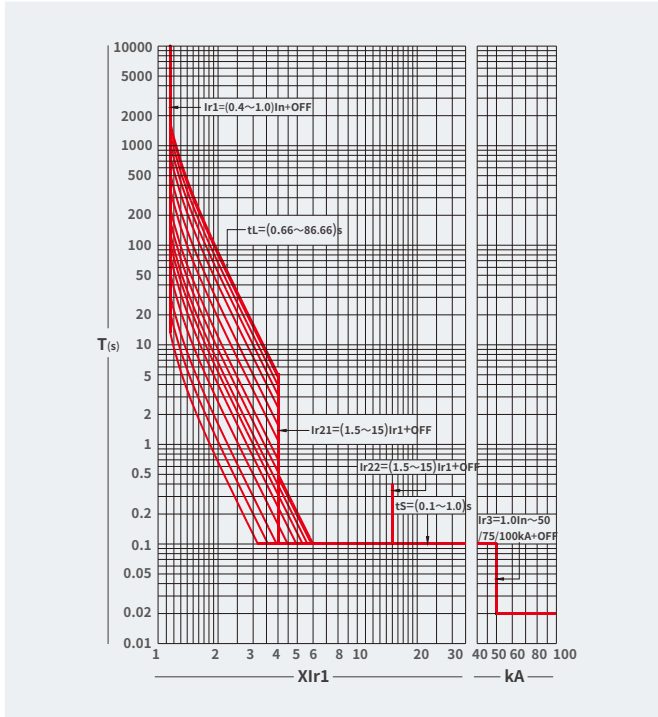

Figure 6. Extremely fast inverse time 2 (general protection)

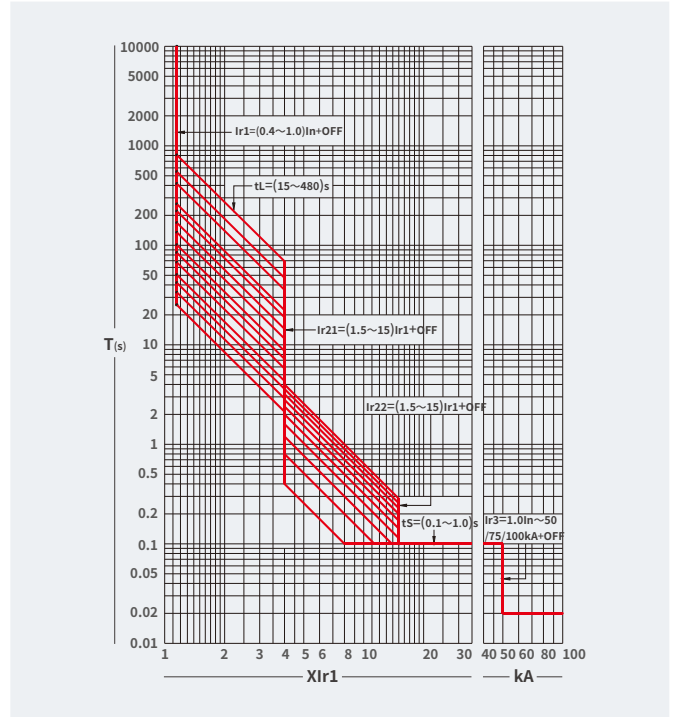

Figure 7. Asymmetric grounding protection

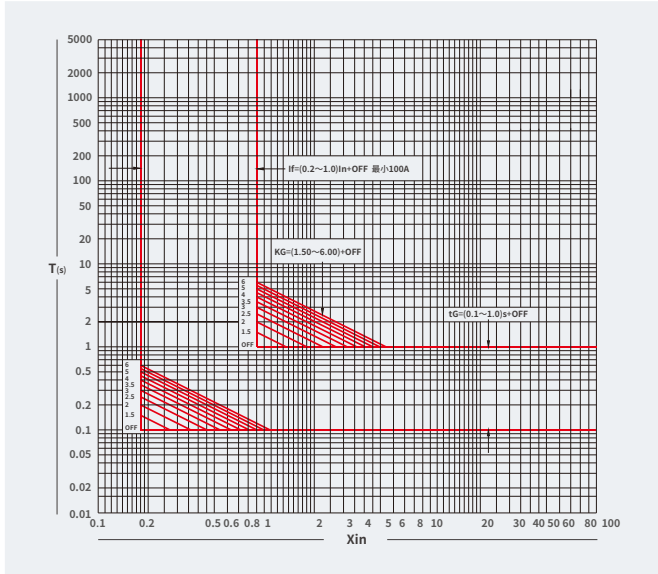
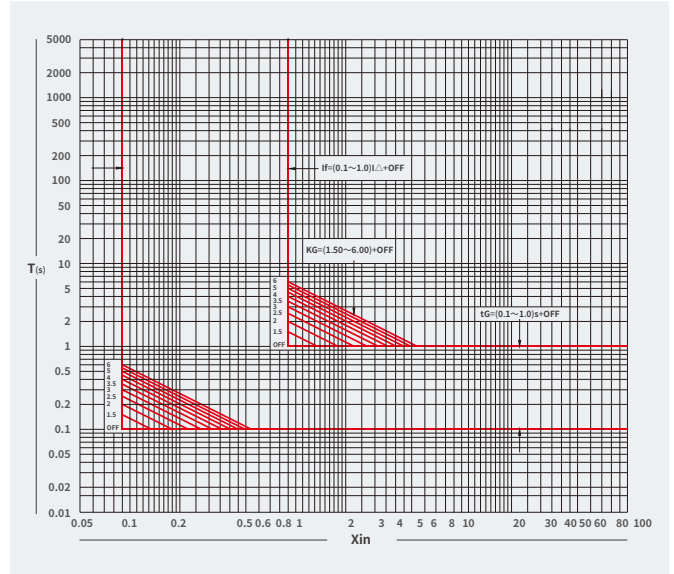

Figure 8. Leakage protection (with external residual current transformer)



### Current setting values Ir and allowable errors of the release

Long delay		Short delay		Instantaneous		Grounding fault	
Ir	Allowable error	Isd	Allowable error	Ii	Allowable error	Ig	Allowable error
$(0.4\sim 1.0)I_n+OFF$	$\pm 10\%$	$(1.5\sim 15)I_n+OFF$	$\pm 10\%$	$(1.0\sim 20)I_n+OFF$	$\pm 15\%$	$(0.2\sim 1.0)I_n+OFF$	$\pm 10\%$

Note: When with three-stage protection, the settings cannot be cross-set, and  $I_r < I_{sd} < I_i$ .

# EXW3 Air Circuit Breaker

## Functions and Features

---

### Function description

- Major protection functions (controller's functions are set to requirements upon factory delivery; please contact us for resetting)  
Includes long delay over-load protection, short-circuit short-time fixed time and inverse time protection, short-circuit instantaneous protection, grounding or residual current fixed time and inverse time protection, N-phase protection, current unbalance protection due to phase loss, and load inverse time monitoring.
- Measurement and operation monitoring  
Real-time measurement of various power grid operating parameters, such as frequency, power factor, active power, etc.; real-time indication of operating status, such as, fault status, alarm status, system self-diagnosis status, normal operation status, and etc.
- Query function  
Operation parameter query, protection parameter setting query, historical fault record query, self-diagnosis fault information query and power grid measurement parameter query
- Parameter setting function  
The following protection parameters can be directly set on the controller panel: overload long delay protection's current and time, short-circuit short delay protection's inverse time current and fixed time current and time, instantaneous protection's current, load monitoring's current and time, N-phase protection settings, grounding or residual current protection's current and time and inverse time coefficient, current unbalance protection's unbalance rate and time, and harmonics Influence factor.
- The following operations can also be performed on the controller panel: system clock adjustment (only available after selected), and setting all internal system parameters that can be set by the programmer (programmer is not required, but authorization password is required).
- Programming interface function  
An interface with the programmer is available, to modify some specific parameters, such as, signal output contact's function setting, voltage measurement's wiring method, system clock, protection characteristic curve, thermal memory function, communication address, communication baud rate, and etc.
- Communication network function (only available for Mic5.0 intelligent controller)The controller provides a standard RS485 interface and ensures data transmission through Modbus or Profibus-DP or DeviceNet protocols, to meet the "four remote" requirements in different monitoring systems.
- Test function  
The test function offers two types: instantaneous tripping simulation test and non-tripping simulation test:  
(1) Instantaneous tripping simulation test: Instantaneous tripping test can be performed on the circuit breaker, with the action time  
(2) inherent to the circuit breaker to be displayed after the action time.  
(3) Non-tripping simulation test: Select simulation test current for the system's non-tripping test. Test current, system delay action time  
(4) under the test current, and fault category of the simulation test will be displayed in turn after the test is completed.
- Self-diagnosis function  
Diagnose and alarm when faults occur in the controller itself.
- Fault clock function (optional)  
Record the time when the fault occurs Th, including the year, month, day, hour, minute and second when the fault occurs, with up to 8 records.
- Historical data recording function (optional)
- Record four-phase current, three-phase voltage, frequency, power, power factor, and active power, every half an hour, for three months.
- Load monitoring protection function  
Load monitoring is to control different loads of the circuit breaker to ensure the power supply to the main loads as much as possible. Load monitoring can be used for pre-alarming and branch load control. The controller can be programmed to output two passive signal contacts for load monitoring.
- MCR ON-OFF and over-limit trip function (optional)  
ON-OFF means that the power grid is already in a fault state before the circuit breaker is closed, a current greater than MCR set value is generated upon closing, and the controller opens the circuit breaker instantaneously through an analog circuit. This function only works at the moment of closing (within 100ms).  
Over-limit tripping means that when the circuit breaker is in normal operation, if the short-circuit current exceeds a certain value (usually the ultimate current of the circuit breaker), the controller will instantaneously break the circuit breaker through an analog circuit. This function is not subject to instantaneous settings.
- Communication protocol  
Includes an internal Modbus-RTU, and can be transferred to Profibus-DP or DeviceNet through an external module.

# EXW3 Air Circuit Breaker

## Functions and Features

### Secondary circuit wiring diagram

- 1) Dotted lines indicate wirings made by users themselves. No wiring is needed when relevant optional accessory is not ordered;
- 2) Power supplies should be connected separately to accessories such as intelligent controller, under-voltage release, shunt release, closing electromagnet, and motor operator, when their voltages are different;
- 3) The under-voltage release is directly connected to the main circuit's incoming end, with its maximum operating voltage not exceeding the rated operating voltage. When the operating voltage of the main circuit is above the rated operating voltage, a transformer is needed to have it drop to the rated operating voltage.
- 4) The cassette three-position indication function is only optional for withdrawable circuit breakers;
- 5) With DC (DC110V, DC24V) operating power supply for the intelligent controller, first connect the ST power module (optional), then the intelligent controller 1#, 2#.

Secondary circuit wiring diagram of Mic5.0 intelligent controllers

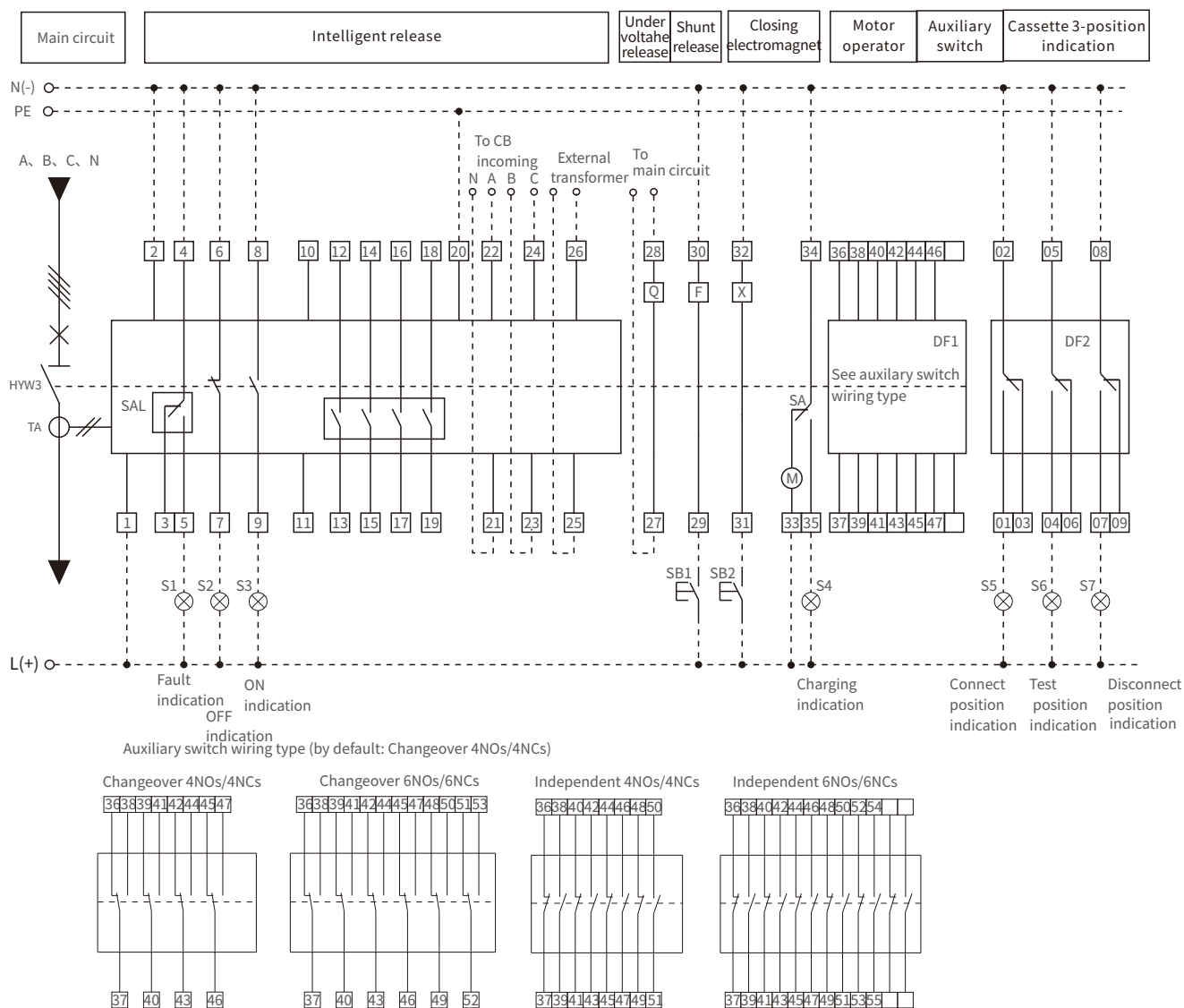

# EXW3 Air Circuit Breaker

## Functions and Features

### Secondary circuit wiring diagram terminal functions of Mic1.0 and Mic2.0 intelligent controllers

Terminal No.	Function description	Remark
1、 2	Auxiliary power input: AC220V、 AC380V、 DC220V、 DC110V	
3、 4、 5	Fault trip auxiliary contact, contact capacity: AC250V、 3A	
6、 7	Circuit breaker status auxiliary contact (NC), contact capacity: AC250V、 3A	
8、 9	Circuit breaker status auxiliary contact (NO), contact capacity: AC250V、 3A	
20	Grounding (PE)	
21、 22、 23、 24	Voltage signal measurement: 21 to N, 22 to A, 23 to B, 24 to C	Optional function
25、 26	External transformer input (residual current transformer, neutral transformer, ground current transformer)	Optional function and accessory
27、 28	Under-voltage release	Optional accessory
29、 30	Shunt release	
31、 32	Closing electromagnet	
33、 34、 35	Motor operator	
36~……	Df1 auxiliary switch terminal	

### Secondary circuit wiring diagram terminal functions of Mic5.0 intelligent controllers

Terminal No.	Function description	Remark
1、 2	Auxiliary power input: AC220V、 AC380V、 DC220V、 DC110V	
3、 4、 5	Fault trip auxiliary contact, contact capacity: AC250V、 3A	
6、 7	Circuit breaker status auxiliary contact (NC), contact capacity: AC250V、 3A	
8、 9	Circuit breaker status auxiliary contact (NO), contact capacity: AC250V、 3A	
10、 11	Communication interface output, 10 to A, 11 connected to B	By default: Modbus
12~19	Signal input and output, 12 and 13 are DO1; 14, 15 are DO2; 16, 17 are DO3; 18, 19 are DO4	Per function requirements
20	Grounding (PE)	
21、 22、 23、 24	Voltage signal measurement: 21 to N, 22 to A, 23 to B, 24 to C	
25、 26	External transformer input (residual current transformer, neutral transformer, ground current transformer)	Optional function and accessory
27、 28	Under-voltage release	Optional accessory
29、 30	Shunt release	
31、 32	Closing electromagnet	
33、 34、 35	Motor operator	
36~……	DF1 auxiliary switch terminal	

# EXW3 Air Circuit Breaker

## Functions and Features

### Wiring diagram legend description

Legend	Description	Remark	Legend	Description	Remark
EXW3	EXW3 series air circuit breaker		PE	Ground wire	
S1~S7	Signal lamp	Supplied by user	L(+), N(-)	Control power supply (DC L for positive, N for negative)	
TA	Current transformer		A, B, C, N	Main circuit phase line	
SAL	Micro switch		DF1	Auxiliary switch	Type optional
SB1	Opening button	Supplied by user	DF2	Cassette 3-position electrical indicating switch	Optional accessory
SB2	Closing button	Supplied by user	ST power module	Provide 24V DC power supply	Optional accessory
X	Closing electromagnet		ST201	Relay	Optional accessory
F	Shunt release		Protocol converter	Except for Modbus protocol, other protocols need to be configured	Optional accessory
Q	Under-voltage release	Optional accessory			
M	Motor operator				
SA	Motor operator travel switch				

Secondary circuit wiring diagram of Mic1.0 and Mic2.0 intelligent controllers

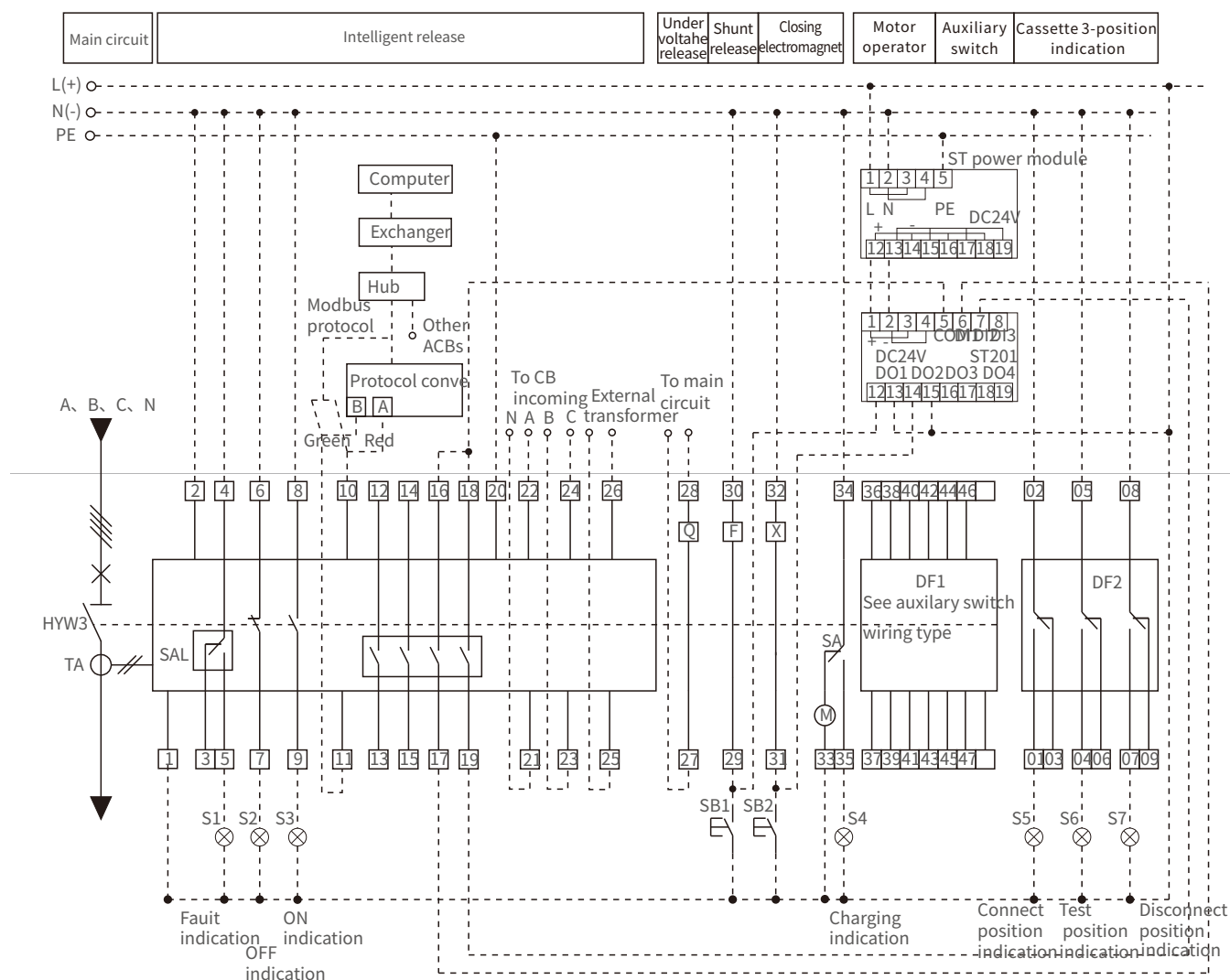

# EXW3 Air Circuit Breaker

## Functions and Features

### Installation and wiring

EXW3-1600 fixed type outlines and mounting dimensions

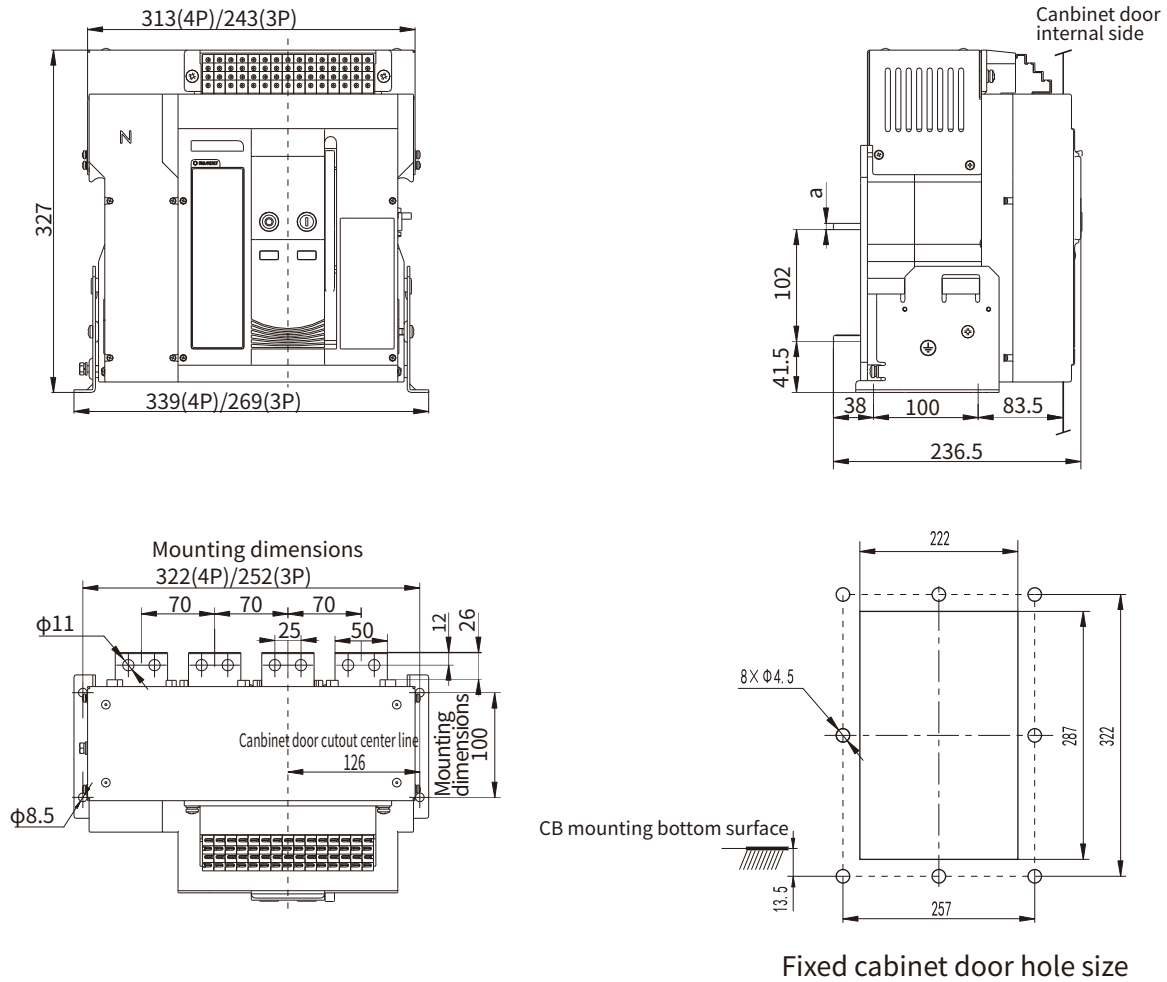

In (A)	a(mm)
$\leq 1250$	10
1600	15

# EXW3 Air Circuit Breaker

## Functions and Features

EXW3-1600 withdrawable type outlines and mounting dimensions  
(select one type from either internal or external mounting dimensions)

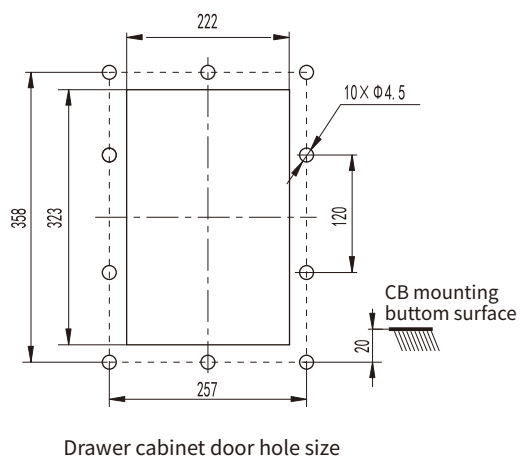
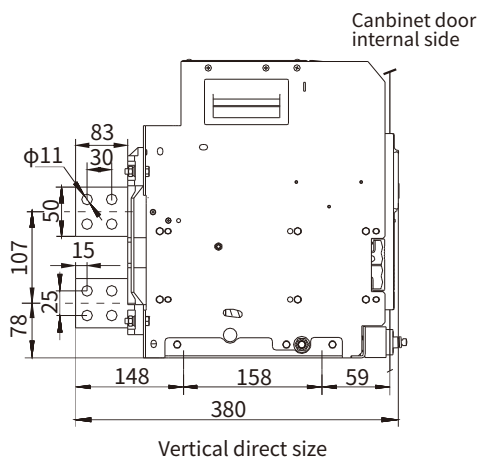
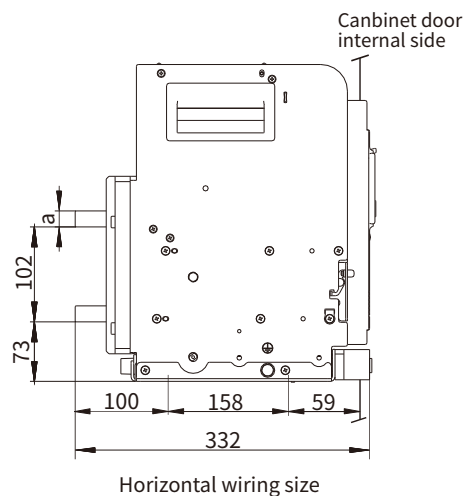
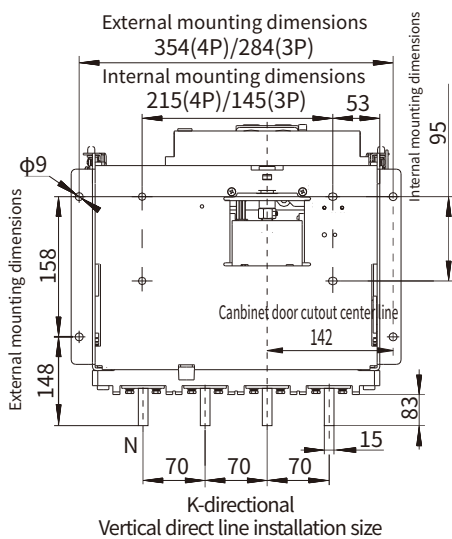
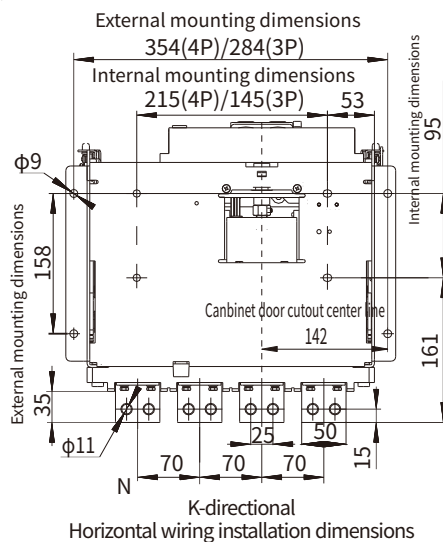
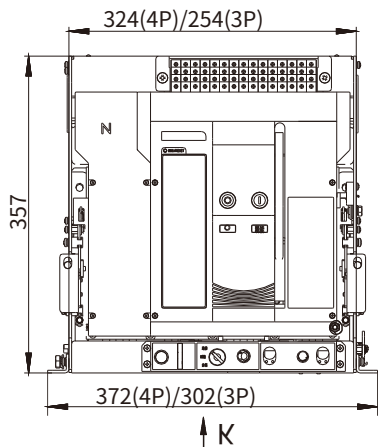

In (A)	a(mm)
≤1250	10
1600	15

# EXW3 Air Circuit Breaker

## Functions and Features

### EXW3-2000/2500 fixed type outlines and mounting dimensions

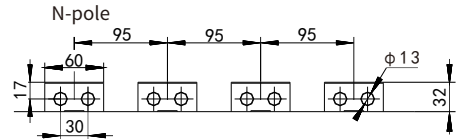
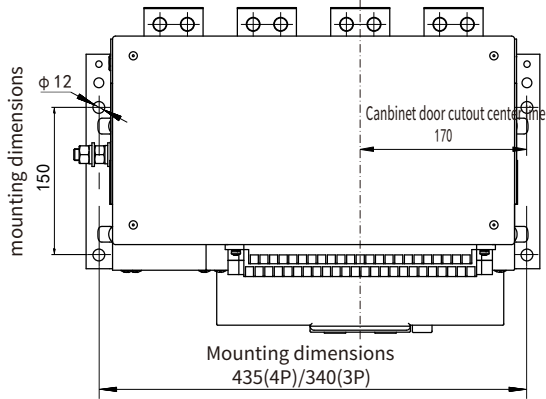
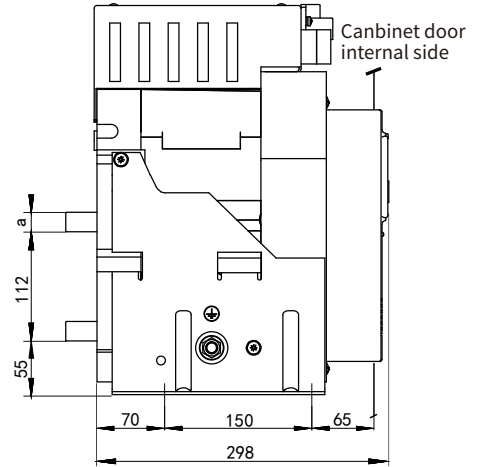
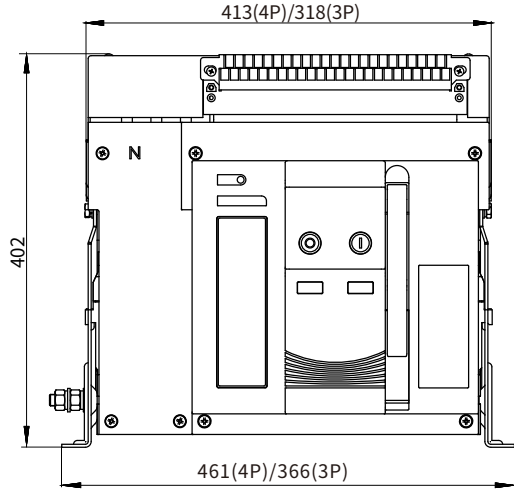

N type 2000A and below horizontal wiring dimensions

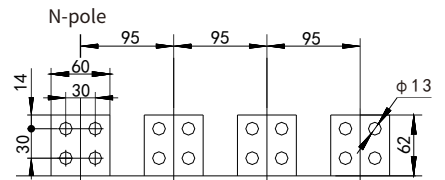

N type 2500A horizontal wiring dimensions

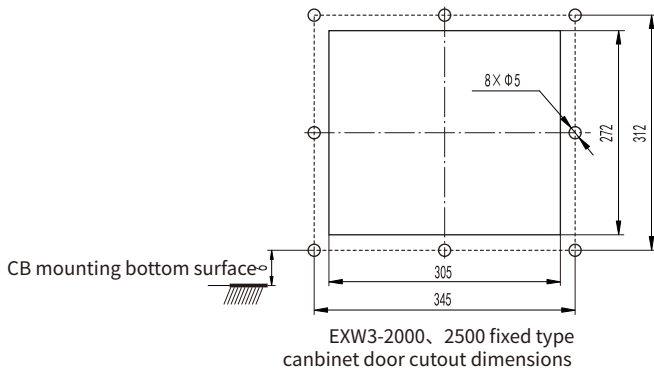

EXW3-2000、2500 fixed type cabinet door cutout dimensions

In (A)	a(mm)
≤1250	10
1600	15
2000	20
2500	20

# EXW3 Air Circuit Breaker

## Functions and Features

EXW3-2000/2500 withdrawable type outlines and mounting dimensions  
(select one type from either internal or external mounting dimensions)

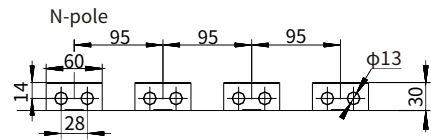
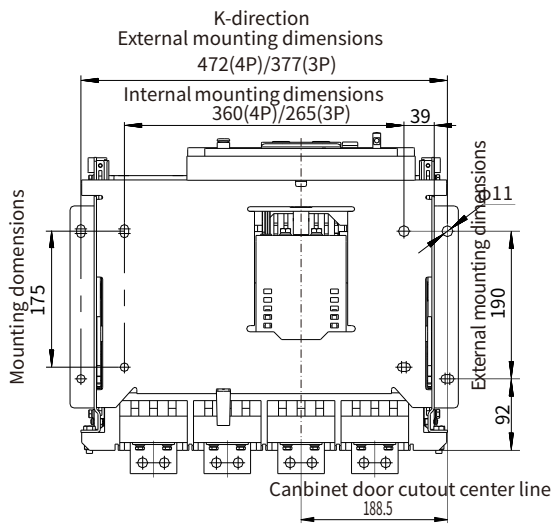
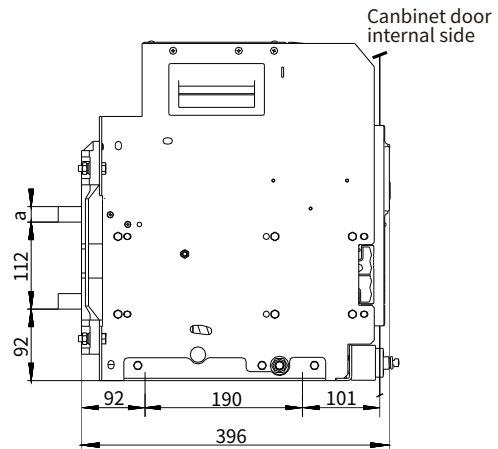
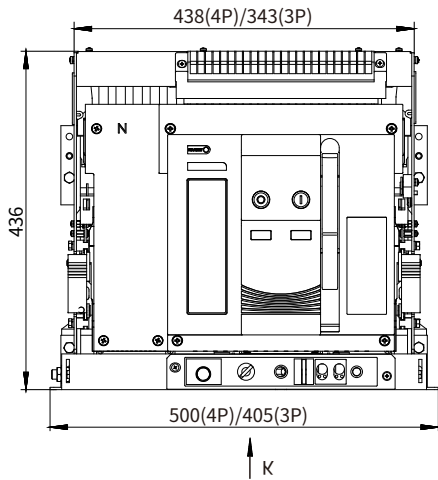

N type 2000A and below horizontal wiring dimensions

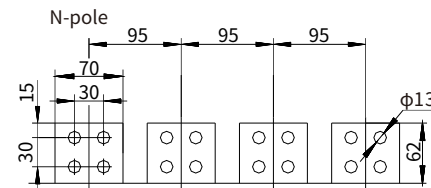

N type 2500A horizontal wiring dimensions

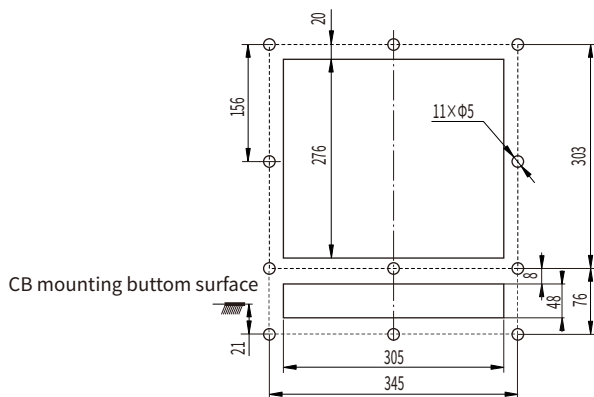

EXW3-2000、2500 Withdrawable  
Cabinet door cutout dimensions

In (A)	a(mm)
≤1250	10
1600	15
2000	20
2500	20

# EXW3 Air Circuit Breaker

## Functions and Features

### EXW3-3200/4000 fixed type outlines and mounting dimensions

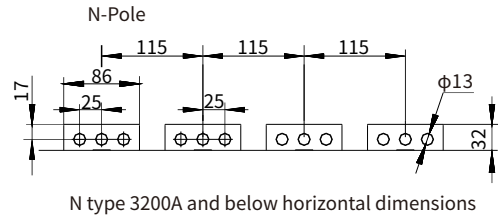
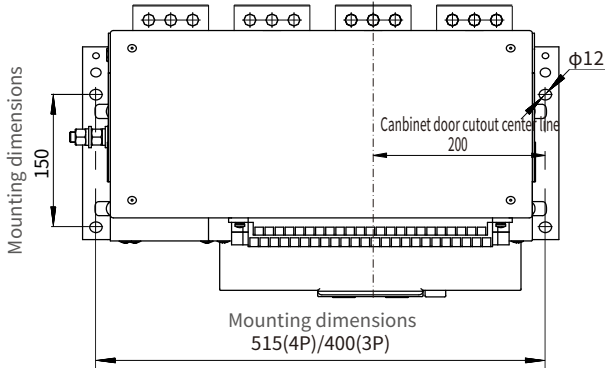
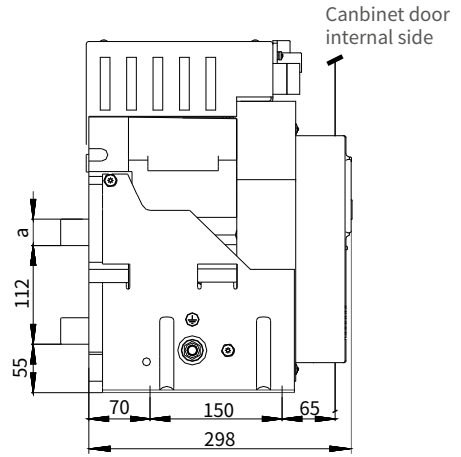
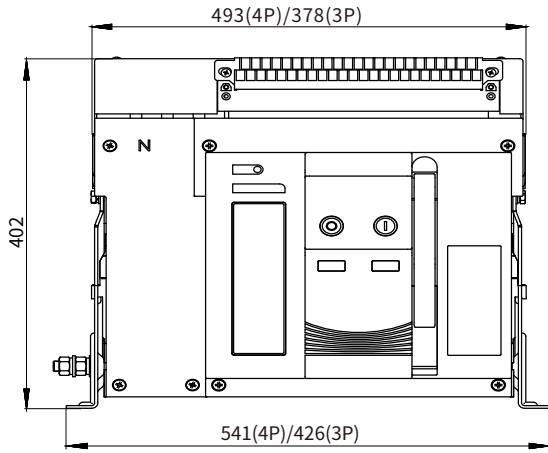

N type 3200A and below horizontal dimensions

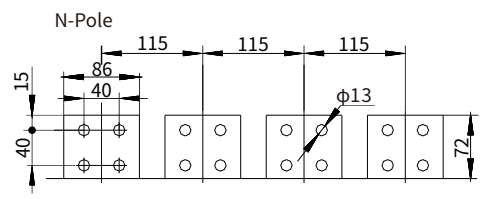

N type 4000A horizontal dimensions

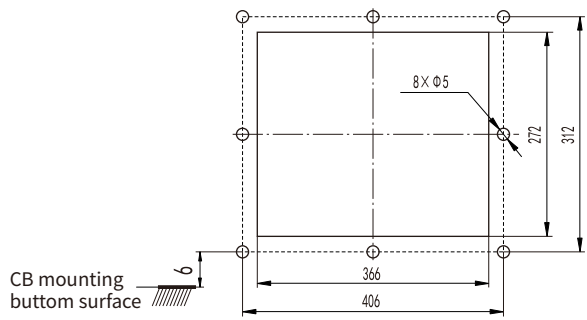

EXW3-3200, 4000 fixed type cabinet door cutout dimensions

In (A)	a(mm)
2000, 2500	20
3200, 4000	30

# EXW3 Air Circuit Breaker

## Functions and Features

EXW3-3200/4000 withdrawable type outlines and mounting dimensions  
(select one type from either internal or external mounting dimensions)

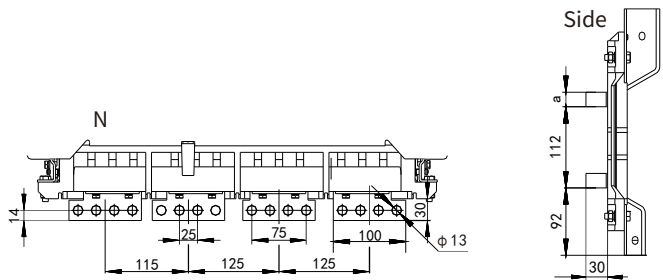
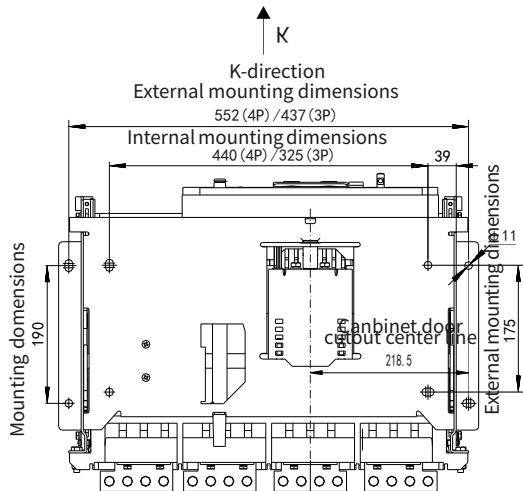
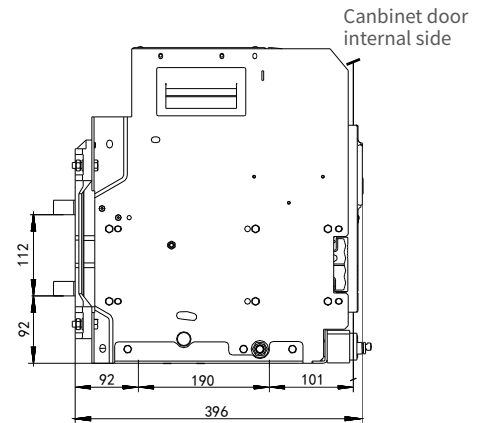
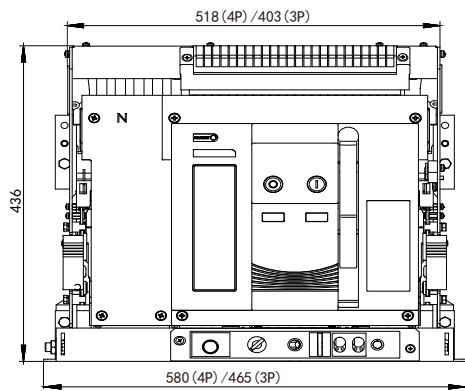

N type 3200A and below horizontal dimensions

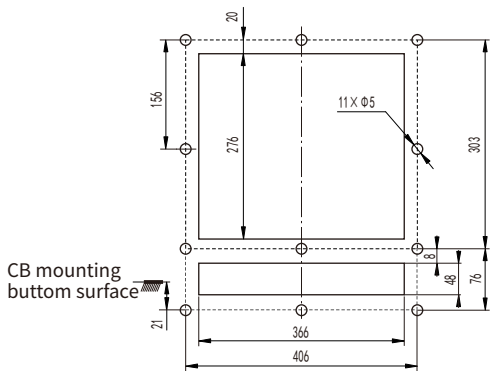

Cabinet door cutout dimensions

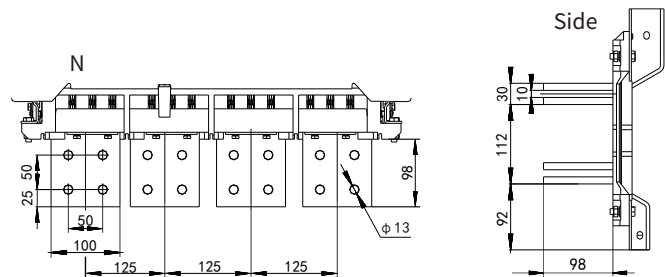

N type 4000A horizontal dimensions

In (A)	a(mm)
2000、2500	20
3200、4000	30

# EXW3 Air Circuit Breaker

## Functions and Features

EXW3-6300 fixed type outlines and mounting dimensions

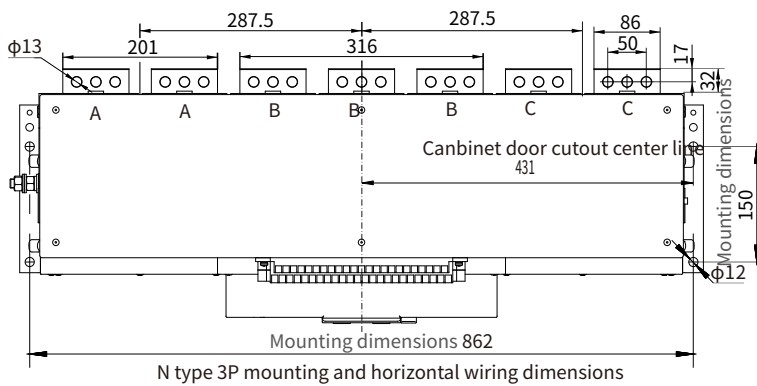
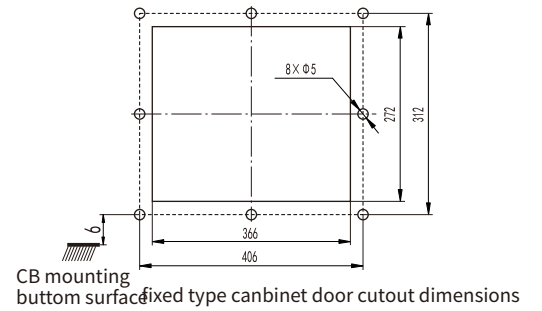
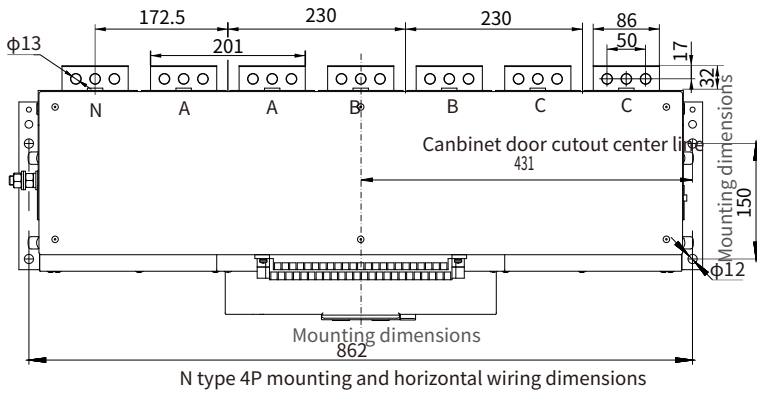
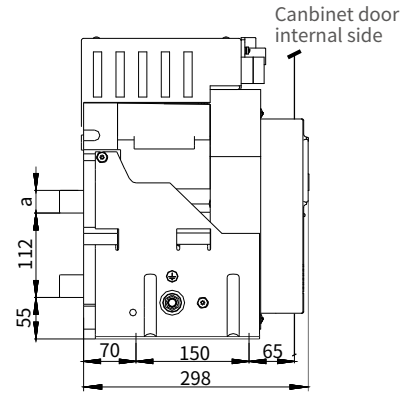
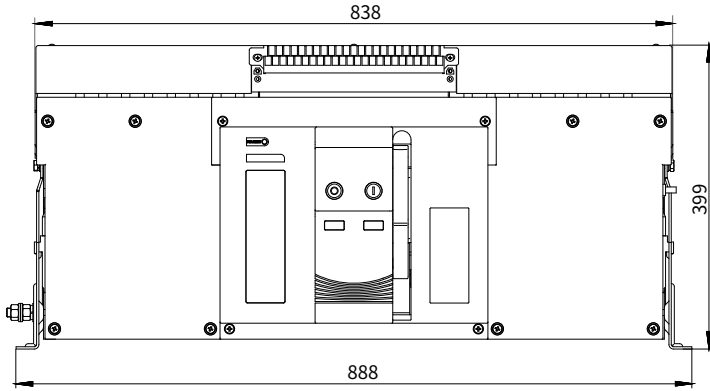

In (A)	a(mm)
4000、5000	20
6300	30

Note: For Phase A、B and C, two wirings in the same phase are to be made by users themselves

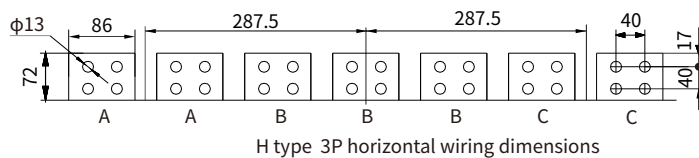



# EXW3 Air Circuit Breaker

## Functions and Features

### Dual-power automatic transfer switch

The dual-power automatic transfer switch (hereafter referred to as ATS) is CB-level, composed of two EXW3 series air circuit breaker, a dual-power transfer controller and a mechanical interlock. It is suitable for use in two-way three-phase four-wire power grids with a frequency of 50Hz/ 60Hz and the rated working voltage of 400V. To order an ATS, note the following:

- a. It is recommended that the dual-power automatic controller should not be purchased separately, to avoid wiring errors from causing damages to circuit breakers and dual-power controllers. The controller should be ordered together with the breaker.
- b. A mechanical interlock must be ordered at the same time.
- c. The length of the dedicated cable for the dual-power automatic controller is 2M, and the length between two circuit breakers is 2M.
- d. Key locks are forbidden for use on circuit breakers equipped with dual power supply automatic controllers
- e. The control power voltage of the shunt release and closing electromagnet of the circuit breaker can only be 220VAC.
- f. Door interlocking in on-off state should not be equipped for circuit breakers with dual-power automatic controllers.
- g. The remotely-controlled circuit breaker cannot offer closing and opening functions when the breaker with a dual power automatic controller is equipped with H-type intelligent controller.
- h. Communication function, fire control function, and generator function are optional.
- i. Under-voltage release should not be equipped for circuit breakers with dual power automatic controllers.

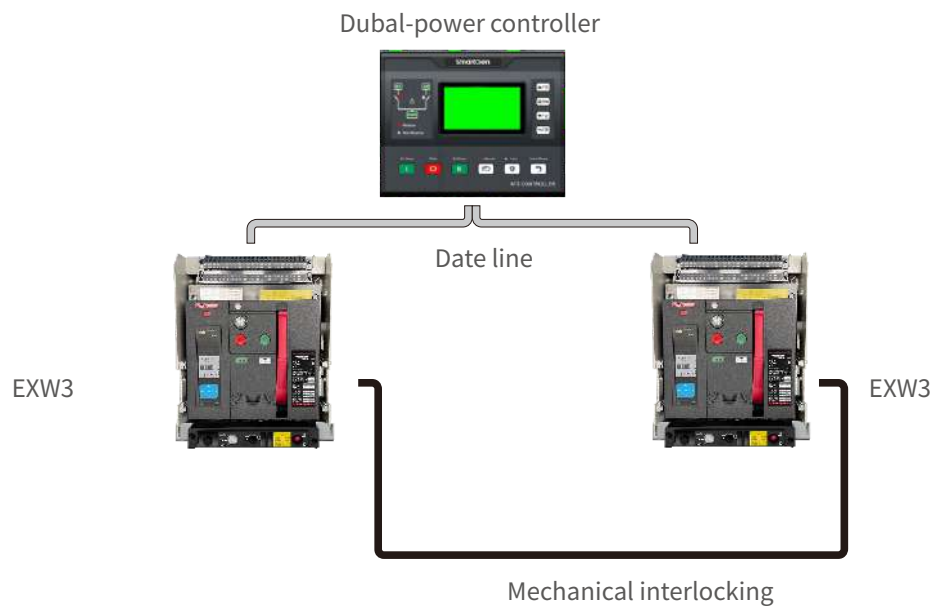

# EXW3 Air Circuit Breaker

## Functions and Features

### Dual power supply controller operation and wiring diagram

Dual power controller interface



Key description

Name	Auto	Manual
Auto/Manual	Auto mode selection key	Manual mode election key
OFF/ESC	Disconnect	Exit
N/+	Common	+(up)
R/-	Spare	-(down)
↵	Confirm (Select)	
Reset	Controller reset	

Indicator light description

Name	Meaning	Remark
N(up)	on: common voltage is abnormal	Both N and R are off: ATS is in OFF position
	off: common voltage is normal	
R(up)	on: the spare voltage is abnormal	
	off: the spare voltage is normal	
N(down)	on: ATS is working in common power	
	off: ATS is not working in common power	
R(down)	on: ATS is working in spare power	
	off: ATS is not working in spare power	

Indicator light description

Name	Meaning
Run	Flashing: controller is working
	Always on or off: controller is in fault state
Alarm	On: ATS has alarm message
	OFF: no alarm message
Auto	On: ATS works in Auto mode
	OFF: ATS works in manual mode
Fire	Fire signal indicator

### Outline and installation dimensions of the ATS controller

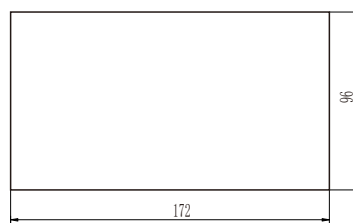
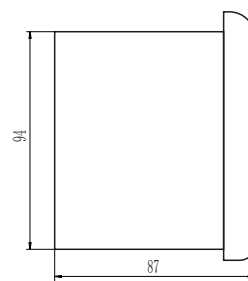
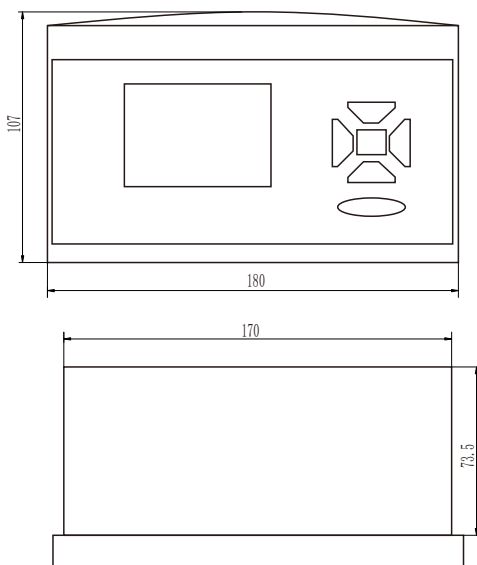

Panel cut-out size

#### Notes:

1. to ensure the normal operation of ATS and prevent operation errors, all ATS controller products need to be equipped with corresponding mechanical interlocking devices; breakers should not be equipped with undervoltage releases and key-locks, otherwise the ATS controller may not work.
2. the switching frequency of the ATS controller should not be too fast, and the interval time should be able to ensure that the breaker is fully stored otherwise the controller will report an error.
3. before powering on the ATS controller, the two breakers should be manually stored.

# EXW3 Air Circuit Breaker

## Functions and Features

### Dual-power controller wiring diagram

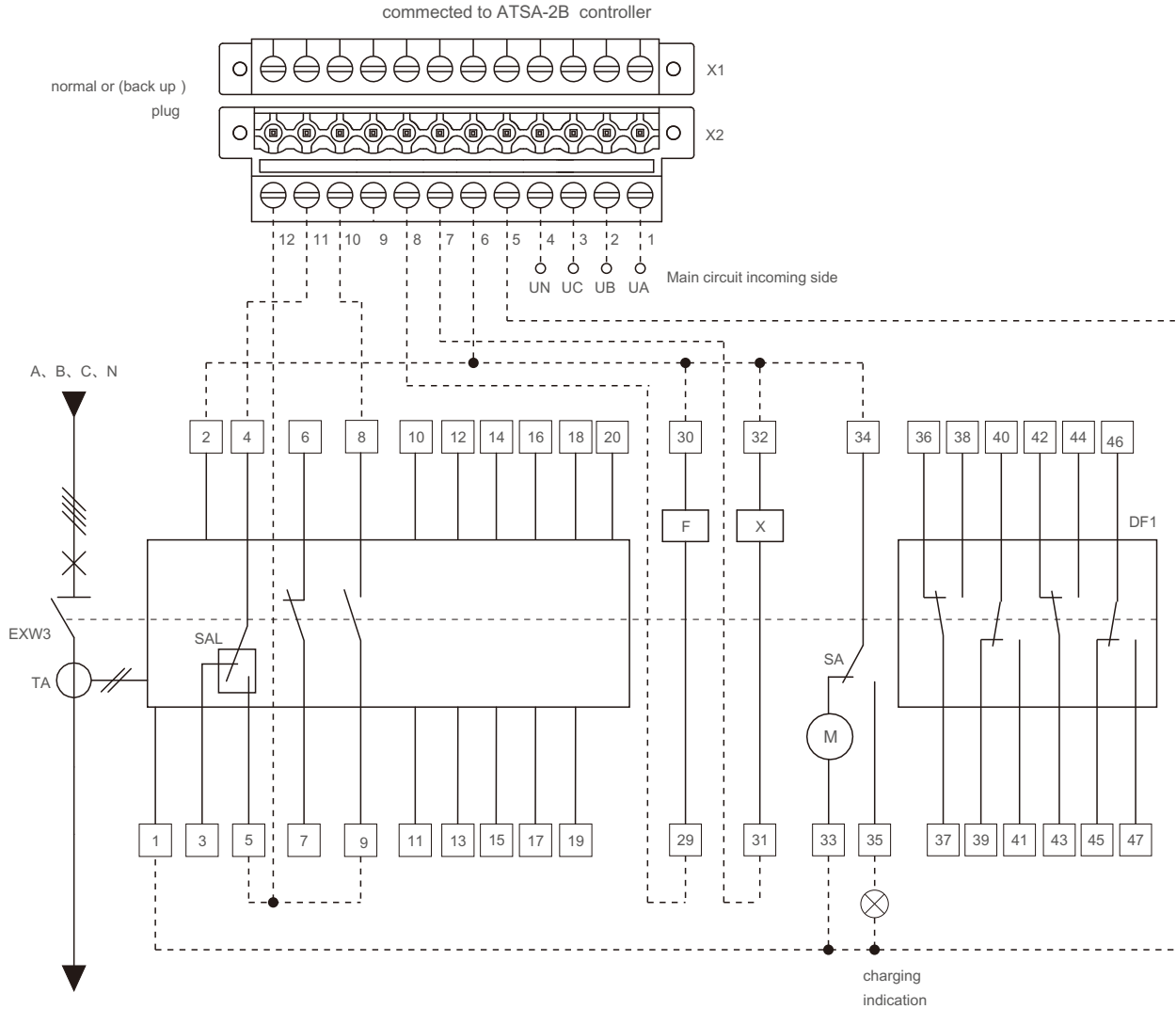

### Dual-power controller wiring terminal description

Terminal No.	Description	CB terminal No. connected	Remark
1 ~ 4	Connected to the main circuit, 1 to UA, 2 to UB, 3 to UC, 4 to UN	Connected to main circuit incoming side by user	
5	Control power output (L)	1, 33	AC230V
6	Control power output (N)	2, 30, 32, 34	
7	Signal output DO3 or DO1, connected to closing electromagnet	31.	
8	Signal output DO4 or DO2, connected to shunt release	29	
9		Reserved	
10	Signal input DI3 or DI1,	8	
11	Signal input DI4 or DI2,	4	
12	Signal input DIV-,	5, 9	

# EXW3 Air Circuit Breaker

## Functions and Features

### Operation and wiring diagram of dual power bus coupler controller

Dual power bus tie controller interface

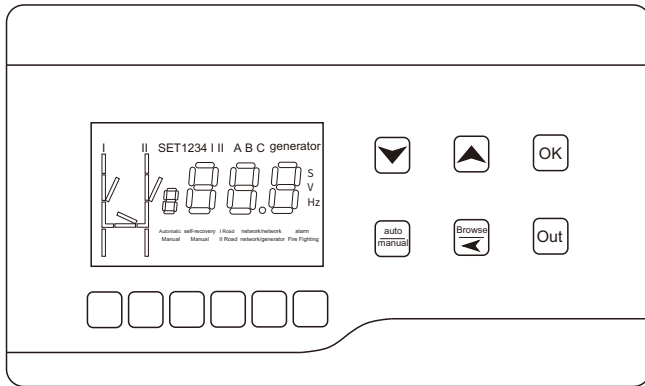

Double power bus tie controller button

Button	Button Setting status meaning	Browsing status meaning
	Select setting items or change parameters	Scroll to browse item
	Select setting items or change parameters	Scroll to browse items
	Enter parameter change, confirm parameter change	Undefined
	1. Switch between manual and automatic modes; 2. Combine with the [Browse] key to enter the setting	Undefined
	modify the numerical parameters to select one, ten, and percentile	Enter browsing state
	Return to the previous setting or exit the setting	Quit browsing state

### Manual operation button



Circuit breaker I closed    Tie breaker open    Circuit breaker I open    Tie breaker open    Circuit breaker I closed    Tie breaker open  
 Circuit breaker I closed    Tie breaker closed    Circuit breaker I open    Tie breaker closed    Circuit breaker I open    Tie breaker open  
 Circuit breaker II open    Circuit breaker II open    Circuit breaker II closed    Circuit breaker II closed    Circuit breaker II closed    Circuit breaker II open

### Controller status display

Setting 1234---Setting 1: User primary setting; Setting 2: User advanced setting; Setting 3, 4: Factory setting;  
 I, II---I: display the parameters of the I road; II: display the parameters of the II road;  
 ABC---A: display A phase parameters; B: display B phase parameters; C: display C phase parameters;  
 Power generation---display "generation" after starting the generator, flashing "generation" when the generator is stopped after a delay;  
 SVHz---display parameter units, respectively: seconds, volts, hertz;  
 8888---digital tube, small digital tube display setting items, large digital tube display parameters;  
 Automatic---The controller is in automatic working mode;  
 Manual---The controller is in manual mode;

Self-recovery---The controller is in self-input and self-recovery mode;  
 Mutual backup---The controller is in the mode of self-input and non-self-recovery;  
 I Road---I Road is commonly used;  
 II Road---II Road is commonly used;  
 Net/Net---The controller is applicable to the grid structure: grid-grid;  
 Grid/Generation---The controller is suitable for grid structure: grid-generator;  
 Alarm --- prompt alarm;  
 Fire Fighting --- There is a fire fighting signal input.

### Outline and installation dimensions of dual power bus coupler controller

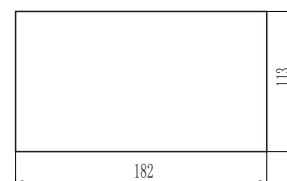
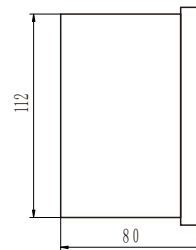
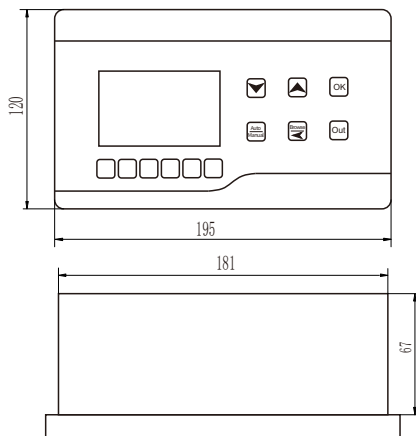

# EXW3 Air Circuit Breaker

## Functions and Features

### Dual-power automatic transfer switch

The dual-power automatic transfer switch (hereafter referred to as ATS) is CB-level, composed of two EXW3 series air circuit breaker, a dual-power transfer controller and a mechanical interlock. It is suitable for use in two-way three-phase four-wire power grids with a frequency of 50Hz/ 60Hz and the rated working voltage of 400V. To order an ATS, note the following:

- It is recommended that the dual-power automatic controller should not be purchased separately, to avoid wiring errors from causing damages to circuit breakers and dual-power controllers. The controller should be ordered together with the breaker.
- A mechanical interlock must be ordered at the same time.
- The length of the dedicated cable for the dual-power automatic controller is 2M, and the length between two circuit breakers is 2M.
- Key locks are forbidden for use on circuit breakers equipped with dual power supply automatic controllers
- The control power voltage of the shunt release and closing electromagnet of the circuit breaker can only be 220VAC.
- Door interlocking in on-off state should not be equipped for circuit breakers with dual-power automatic controllers.
- The remotely-controlled circuit breaker cannot offer closing and opening functions when the breaker with a dual power automatic controller is equipped with H-type intelligent controller.
- Communication function, fire control function, and generator function are optional.
- Under-voltage release should not be equipped for circuit breakers with dual power automatic controllers.

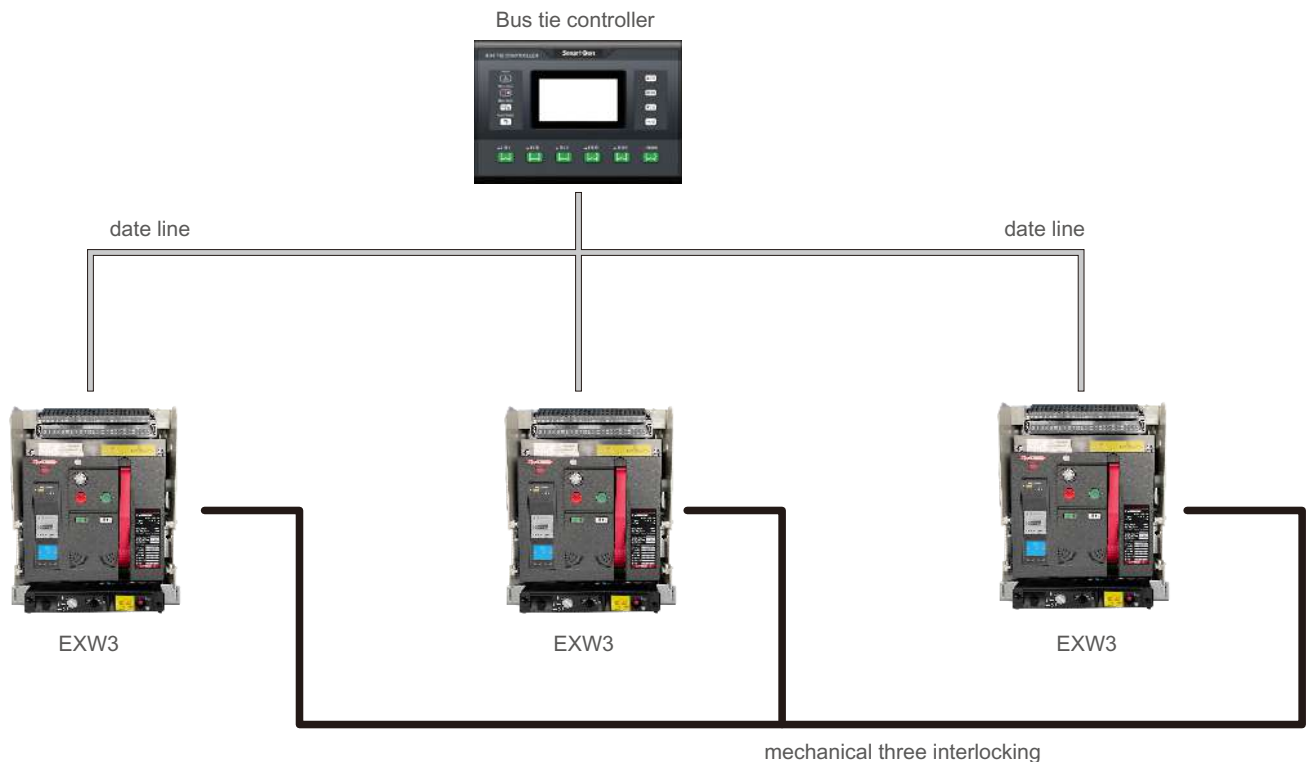

# EXW3 Air Circuit Breaker

## Functions and Features

### Dual-power bus tie controller wiring diagram

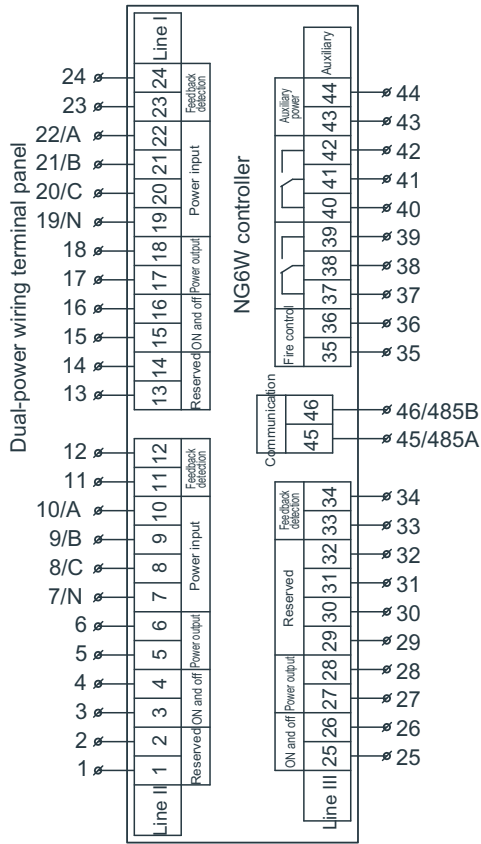
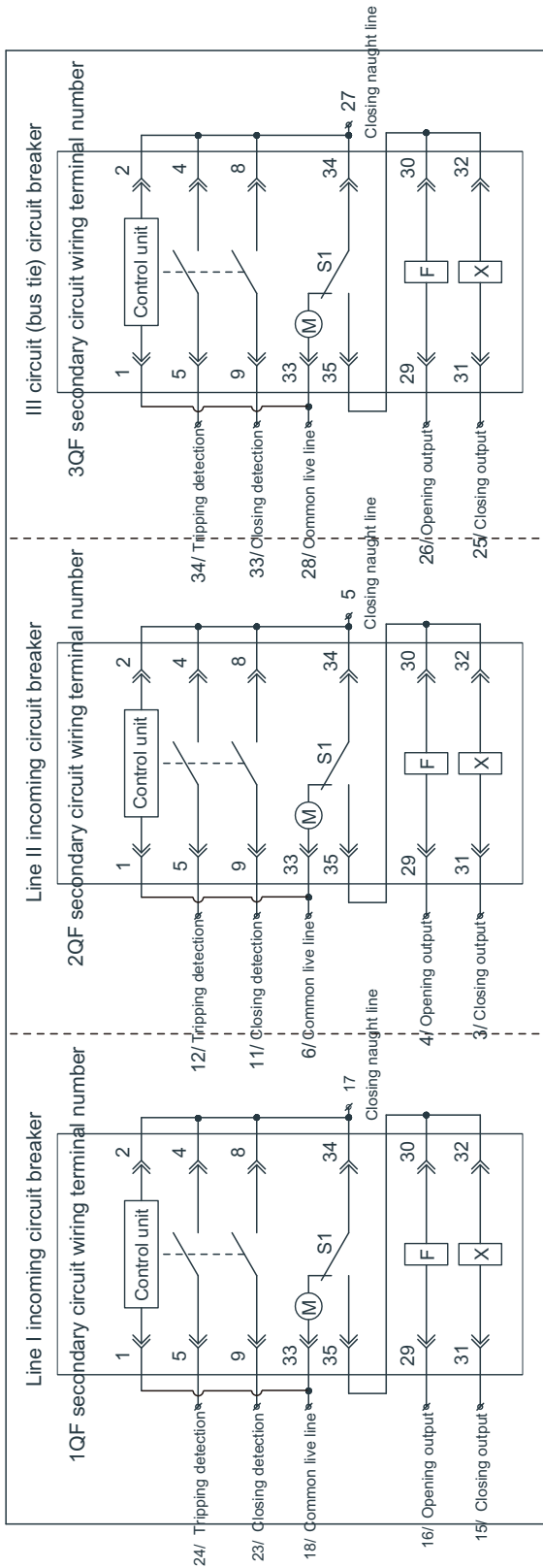

**Supplementary explanation**

35, 36	Fire control signal input (default 24V/AC, DC)
37	Programmable relay 2
38	Programmable relay 1
39	Auxiliary power (24-36V/AC/DC)
40	Communication 485A
41	Communication 485B
42	
43, 44	Auxiliary power (24-36V/AC/DC)
45	Communication 485A
46	Communication 485B

Note 1: Generator start signal control terminals 37, 38 (normally closed) or 38 and 39 (normally open) are wired by the user;

Note 2: An auxiliary interlock switch must be connected in series between the closing output of the controller and the closing electromagnet of the circuit breaker, if the closing electrical interlock is required. The dotted lines

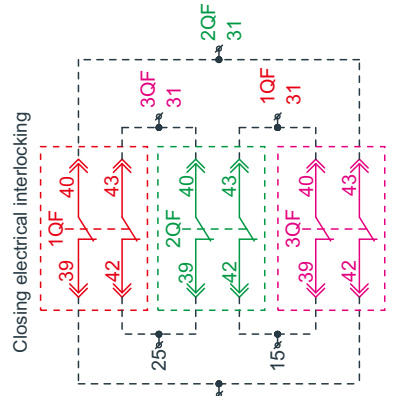

Legend description: 1QF for Line I circuit breaker; 2QF for Line II circuit breaker; 3QF for bus tie breaker; F for shunt release; X for closing electromagnet

Note: Within Box I, II, and III are the circuit breaker's secondary circuit wiring terminal numbers. Outside the boxes are the corresponding terminal numbers of the dual-power bus tie controller, with wirings to be made by users outside the boxes.

Important note: To ensure the normal operation of dual-power products and avoid operating errors, all equipped dual-power controllers need to be equipped with corresponding mechanical interlocking devices.

# EXW3 Air Circuit Breaker

## Functions and Features

### Accessories



2000A and above frame size shunt release

#### • Closing electromagnetic

The closing electromagnet offers remote control to close the circuit breaker quickly, after the circuit breaker is fully charged and back in normally open state.

Operating voltage Us	AC230V	AC400V	DC220V	DC110V
Operating voltage range	(85~110)%Us			
Starting current	1.3A	0.7A	1.3A	2.5A
Circuit breaker response time	=60ms			



2000A and above frame size closing electromagnet

#### • Shunt release

The shunt release offers remote control to open the circuit breaker quickly, when the circuit breaker is in closed state.

Operating voltage Us	AC230V	AC400V	DC220V	DC110V
Operating voltage range	(70~110)%Us			
Starting current	1.3A	0.7A	1.3A	2.5A
Circuit breaker response time	=30ms			



2000A and above frame size under-voltage release

#### • Under-voltage release

When the undervoltage release is not powered on, the circuit breaker cannot be closed; the undervoltage release of 2500A and above frame size offer two types: absorbing-assisted (without delay function) and self-absorbing;

Operating voltage Us	AC230V	AC400V
Opening voltage range	(35~70)%Ue	
Reliable closing voltage range	(85~110)%Ue	
No closing voltage range	=35%Ue	
Power loss	20VA	
Delay tripping time	Instantaneous, 0.5s, 1s, 3s, 5s	

Note 1: Within 1/2 delay tripping time, the circuit breaker will not open when the operating voltage is restored to above 85% Ue;

Note 2: In areas with frequent thunder and lightning, and at power grids with unstable power supply voltage, it is recommended to use an under-voltage release with delay function to prevent the circuit breaker from being opened due to short-time voltage drop;

Note 3: The maximum delay time for under-voltage delay tripping time is 10s, and up to 5s for maximum zero-voltage delay tripping time (Consult the manufacturer upon ordering).

#### • Inter-phase partition

The inter-phase partition is mounted vertically between wiring busbars at each phase of the circuit breaker, to increase inter-phase insulation capacity



Inter-phase partition

# EXW3 Air Circuit Breaker

## Functions and Features



2000A and above frame size charging motor

### • Charging motor

Motor charging can be achieved for the circuit breaker with automatic recharging after the breaker is closed, to enable the breaker to perform closing operation again immediately after opened.

Operating voltage Us	AC230V	AC400V	DC220V	DC110V
Operating voltage range	(85~110)%Us			
Charging time	=7s(Cycle time :=once/min)			
EXW3-1600 power loss	75VA		75VA	
EXW3-2000 power loss	85VA		85VA	
EXW3-4000 power loss	110VA		110VA	
EXW3-6300 power loss	150VA		150VA	



2000A and above frame size auxiliary switch

Note: Manual charging operation can also be performed during circuit breaker maintenance

### • Auxiliary switch

Default type: Changeover 4NOs/4NCs

Other types: Independent 4NOs/4NCs, changeover 6NOs/6NCs, independent 6NOs/6NCs

Rated operating voltage	AC230V	AC400V	DC220V	DC110V
Conventional thermal current	6A			
Rated control capacity	300VA		60VA	



Key lock

### • Key lock

Circuit breaker unlocking operation:

The key can be inserted into the lock when the gap on the key corresponds to the red dot of the lock. Turn the key clockwise to the rightmost position, that is, to-unlock state. At this point, the key cannot be pulled out directly, and the circuit breaker can be closed.

Circuit breaker locking operation:

First, press the breaker's opening button, and then turn the key counterclockwise to the leftmost position to remove the key. At this point, the circuit breaker cannot be closed.

Note 1: The following example about power supply modes is for reference only. Interlocking devices can be mounted according to the actual power supply system needs on site. Or consult the manufacturer.

Mode 1: 1 power supply / 1 load

circuit diagram possible operating

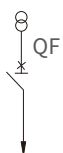

mode	QF
	0
	1

### • One lock and one key

A circuit breaker is equipped with a lock and a key. In the locked state, it is not allowed to close the circuit breaker.

Note 1: QF for HYW3 circuit breakers; 0 for circuit breaker opening; 1 for circuit breaker closing

# EXW3 Air Circuit Breaker

## Functions and Features

### 1: Withdrawable circuit breaker

The withdrawable circuit breaker is composed of the basic device and drawer. On both sides of the cassette, there are guide rails with movable guide plates on them, and the circuit breaker's basic device seats on the left and right guide plates. The withdrawable circuit breaker is connected to the main circuit by plugging the busbar of the basic device into the bridge contact on the cassette. Rotate the racking handle in the lower support of the cassette, to achieve three working positions of the withdrawable circuit breaker (position indications near the racking handle).

- "Connect" position: The main circuit and secondary circuit are both connected.

- "Test" position: The main circuit is disconnected and separated by the insulating partition. Only the secondary circuit is connected, and the necessary operating test can be performed.

- "Disconnect" position: The main circuit and secondary circuit are both disconnected. To remove the basic device in the "Disconnect" position, remove the racking handle first.

The withdrawable circuit breaker is equipped with a mechanical interlocking device, and can be closed only in Connect position or the test position. It cannot be closed between the "Connect" and "Test" positions

### 2: Interlocking mechanism

The interlocking mechanism is mounted on the right-side panel of the circuit breaker.

Use a steel cable interlocking for circuit breakers placed side by side (Figure 4). And use a connecting rod interlock for circuit breakers placed in stack (Figure 5). When one circuit breaker is in the closed state, the other cannot be closed. The interlocking mechanism is installed by users themselves.

Figure 8. Interlocking circuit breakers placed side by side

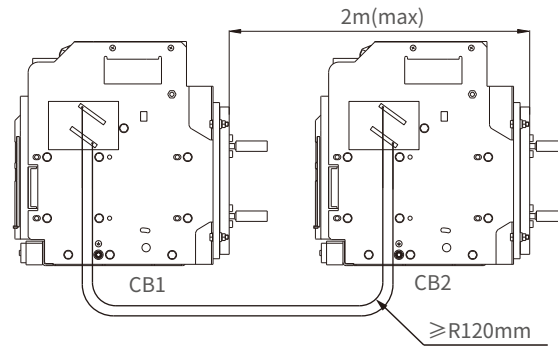
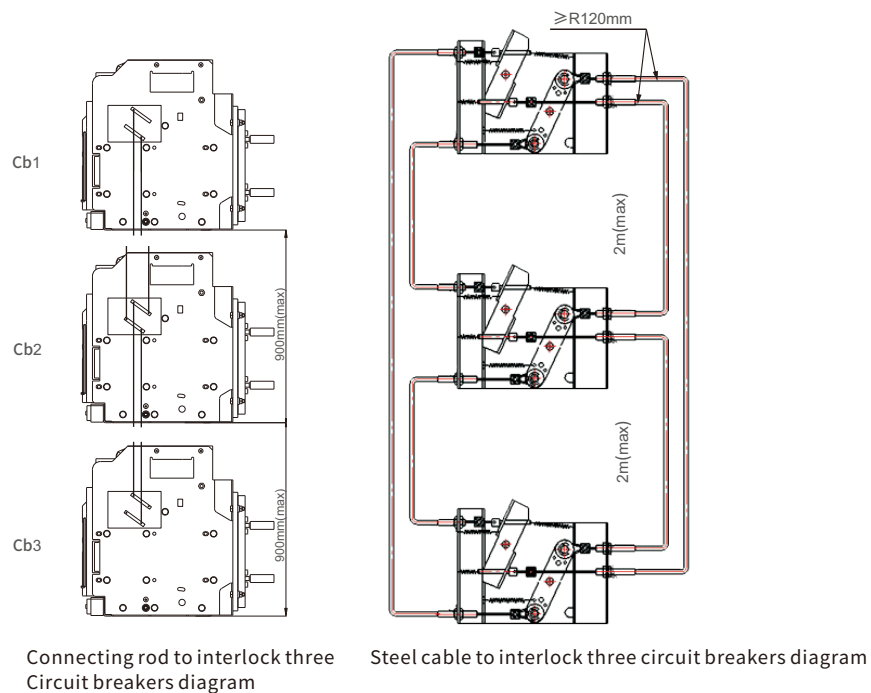

Figure 9. Use a connecting rod interlock for circuit breakers placed in stack (Figure 9 is for three breakers. To interlock two breakers, just remove the top one)



Connecting rod to interlock three  
Circuit breakers diagram

Steel cable to interlock three circuit breakers diagram

# EXW3 Air Circuit Breaker

## Functions and Features

### Accessory

Company:	Contact person:	Contact number:	Order QTY:	( units )	Order date :	
Product model	<input type="checkbox"/> EXW3-1600	<input type="checkbox"/> EXW3-2000	<input type="checkbox"/> EXW3-2500	<input type="checkbox"/> EXW3-3200	<input type="checkbox"/> EXW3-4000	<input type="checkbox"/> EXW3-6300
	<input type="checkbox"/> N	<input type="checkbox"/> N	<input type="checkbox"/> N	<input type="checkbox"/> N	<input type="checkbox"/> N	<input type="checkbox"/> N
Rated current	<input type="checkbox"/> 200 <input type="checkbox"/> 400 <input type="checkbox"/> 630 <input type="checkbox"/> 800 <input type="checkbox"/> 1000 <input type="checkbox"/> 1250 <input type="checkbox"/> 1600	<input type="checkbox"/> 630 <input type="checkbox"/> 800 <input type="checkbox"/> 1000 <input type="checkbox"/> 1250 <input type="checkbox"/> 1600 <input type="checkbox"/> 2000	<input type="checkbox"/> 2500	<input type="checkbox"/> 2000 <input type="checkbox"/> 2500 <input type="checkbox"/> 3200	<input type="checkbox"/> 4000	<input type="checkbox"/> 4000 <input type="checkbox"/> 5000 <input type="checkbox"/> 6300
Number of poles	<input type="checkbox"/> 3P <input type="checkbox"/> 4P					
Mounting method	<input type="checkbox"/> Fixed type <input type="checkbox"/> Withdrawable type					
Breaking capacity	<input type="checkbox"/> N:basic type <input type="checkbox"/> H:high breaking type					
Intelligent controller selection	Type	<input type="checkbox"/> Mic1.0(standard type, digital display) <input type="checkbox"/> Mic2.0(multi-function type, LCD display) <input type="checkbox"/> Mic5.0(intelligent type, LCD display with communication)				
	Rated voltage	<input type="checkbox"/> AC230V <input type="checkbox"/> AC400V <input type="checkbox"/> DC220V <input type="checkbox"/> DC110V <input type="checkbox"/> DC24V				
	Protection data setting	Factory default setting : Ir=1In , Tr=15s ; fixed time I <sub>sd</sub> =8I <sub>r</sub> , T <sub>sd</sub> =0.4s ; inverse time I <sub>s</sub> =4I <sub>r</sub> ; I <sub>i</sub> =1.2I <sub>n</sub> ; I <sub>g</sub> =OFF (opening default value I <sub>g</sub> =I <sub>n</sub> , inverse time shearing factor k = OFF, T <sub>g</sub> =0.4s )				
		Long delay protection I <sub>r</sub>	I <sub>r</sub> = _____ I <sub>n</sub> (from 0.4 to 1.0, or OFF) Tr(1.5 I <sub>r</sub> )= _____ s(from 15, 30, 60, to 960)			
		Short-circuit short delay protection I <sub>sd</sub>	I <sub>sd</sub> = _____ I <sub>r</sub> (from 1.5 to 15, or OFF) <input type="checkbox"/> Fixed time T <sub>sd</sub> = _____ s(from 0.1 to 0.4)			
		Short-circuit I <sub>i</sub>	I <sub>i</sub> = _____ I <sub>n</sub> (from 1.0 to 20, or OFF), max. = 100kA			
Ground protection I <sub>g</sub>	I <sub>g</sub> = _____ I <sub>n</sub> (from 0.2 to 1.0, or OFF) T <sub>g</sub> = _____ s(from 0.1 to 1.0) Inverse time shearing factor k= _____ (from 1.5 to 6, or OFF)					
Optional function	<input type="checkbox"/> Voltage measurement <input type="checkbox"/> Frequency measurement <input type="checkbox"/> Voltage unbalance rate measurement <input type="checkbox"/> Phase sequence detection <input type="checkbox"/> Power measurement <input type="checkbox"/> Power factor measurement <input type="checkbox"/> Temperature control monitoring <input type="checkbox"/> Electric energy measurement <input type="checkbox"/> Zone interlock (ZSI) function <input type="checkbox"/> Harmonic measurement <input type="checkbox"/> Over-voltage protection <input type="checkbox"/> Under-voltage protection <input type="checkbox"/> Voltage unbalance protection <input type="checkbox"/> Over-frequency protection <input type="checkbox"/> Under-frequency protection <input type="checkbox"/> Phase sequence protection <input type="checkbox"/> Reverse power protection <input type="checkbox"/> Demand protection <input type="checkbox"/> Demand measurement (current, power) <input type="checkbox"/> Residual operating current protection <input type="checkbox"/> Load monitoring function <input type="checkbox"/> Neutral line protection <input type="checkbox"/> DI input function <input type="checkbox"/> DO output function <input type="checkbox"/> Communication function: Modbus protocol (Mic5.0 standard) <input type="checkbox"/> Internet of things function (wifi GPRS)					
Accessory equipped as standard	Closing electromagnet	<input type="checkbox"/> AC230V <input type="checkbox"/> AC400V <input type="checkbox"/> DC220V <input type="checkbox"/> DC110V				
	Shunt release	<input type="checkbox"/> AC230V <input type="checkbox"/> AC400V <input type="checkbox"/> DC220V <input type="checkbox"/> DC110V				
	Motor charger	<input type="checkbox"/> AC230V <input type="checkbox"/> AC400V <input type="checkbox"/> DC220V <input type="checkbox"/> DC110V				
	Auxiliary switch	<input type="checkbox"/> Changeover (4NOs/4NCs) <input type="checkbox"/> Independent (4NOs/4NCs) <input type="checkbox"/> Changeover (6NOs/6NCs) <input type="checkbox"/> Independent (6NOs/6NCs) <input type="checkbox"/> Special type				
	Escutcheon sealing ring	<input type="checkbox"/> Fixed type <input type="checkbox"/> Withdrawable type				
Under-voltage release	<input type="checkbox"/> Self-absorbing <input type="checkbox"/> Absorbing-assist (by default)					
	<input type="checkbox"/> AC230V <input type="checkbox"/> AC400V					
	<input type="checkbox"/> Instantaneous <input type="checkbox"/> 0.5s <input type="checkbox"/> 1s <input type="checkbox"/> 3s <input type="checkbox"/> 5s <input type="checkbox"/> Instantaneous (by default)					
Optional accessory	Key lock	<input type="checkbox"/> One circuit breaker with one lock and one key <input type="checkbox"/> Two circuit breakers with two locks and one key <input type="checkbox"/> Three circuit breakers with three locks and two keys <input type="checkbox"/> Special type (can be customized to user requirements)				
	Mechanic interlocking	Two circuit breakers <input type="checkbox"/> Lever interlock (upper and lower interlock) <input type="checkbox"/> Steel cable interlock				
		Three circuit breakers <input type="checkbox"/> Lever interlock (upper and lower interlock) <input type="checkbox"/> Steel cable interlock (Remarks: two methods - two closings/one opening or one closing/two openings - are available)				
	Dual-power controller	<input type="checkbox"/> Dual power supply <input type="checkbox"/> Three power supply <input type="checkbox"/> Two power supply + bus tie (Remarks: with fire control, generator or communication functions, please specify)				
Others	<input type="checkbox"/> Leakage current transformer <input type="checkbox"/> N-phase current transformer <input type="checkbox"/> Ground current transformer <input type="checkbox"/> Power adapter <input type="checkbox"/> Door interlock <input type="checkbox"/> Relay module <input type="checkbox"/> Protocol conversion module(Profibus-DP、Device Net ) <input type="checkbox"/> Cassette electrical three-position lock <input type="checkbox"/> Charging-ready electrical indication <input type="checkbox"/> ON/OFF button lock					

Note 1: Please consult the manufacturer prior to ordering for additional special requirements ;

Note 2: Optional functions and accessories are not included in the standard offering of the circuit breaker. Please order them separately

Note 3: Mechanical interlock should be selected together with the dual-power supply controller



Unlock More: Scan Now

**HUANYU HIGH-TECH CO.,LTD.**

ADD: Wenzhou Bridge Industrial Zone, Yueqing, Zhejiang, China.

WhatsApp/MOB: 0086-135 0655 2522

Email: [austin@huyu.com.cn](mailto:austin@huyu.com.cn)

[www.huyuelectric.com](http://www.huyuelectric.com)

Version number: HUYU202503 (Due to the continuous updating of product technology, all data should be based on the latest confirmation of the company's technical departments.)