



HUW9 ACB

PRODUCT CATALOG

F
U
J
I
N
T



HUANYU HIGH TECH CO.,LTD.
HUYUELECTRIC.COM

HUW9 Air Circuit Breaker

Functions and Features

Structure description

Circuit breaker description

The circuit breaker structure is compact and has modular characteristics. The contact system is enclosed between two insulating base plates with partition structure, each phase contact is separated to form an independent small chamber, and the intelligent controller, operating mechanism, manual and electric operating mechanism are arranged in front of each other to form their respective independent units, if one unit, the whole unit can be removed and replaced (see Fig. 6, Fig. 7).

Figure 1. Operating instruction diagram of EXW3 series air circuit breaker

- 1 Fault reset button
- 2 Intelligent controller
- 3 Opening button
- 4 Closing button
- 5 ON/OFF indicator
- 6 Energy-storage/Release indicator
- 7 Energy-storage handle
- 8 Racking-handle entry
- 9 3-position indication
- 10 Secondary wiring terminal
- 11 Nameplate
- 12 3-position lock



HUW9 Air Circuit Breaker

Functions and Features

Figure 2. Internal diagram of HUW9 series air circuit breaker

- 1 Secondary wiring terminal (basic device)
- 2 Shunt release
- 3 Closed electromagnet
- 4 Auxiliary contact
- 5 Motor operating mechanism
- 6 Operating mechanism

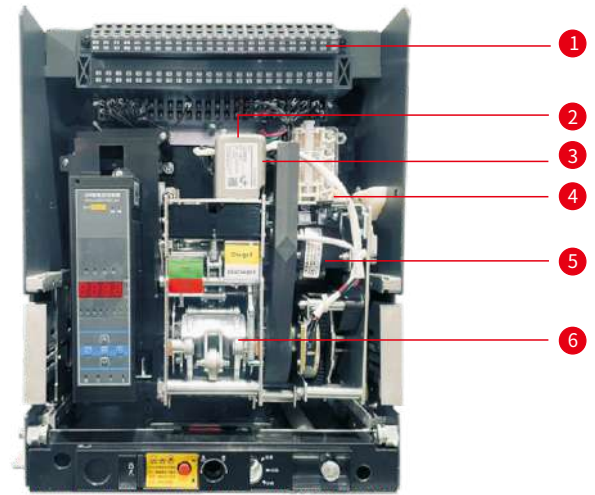
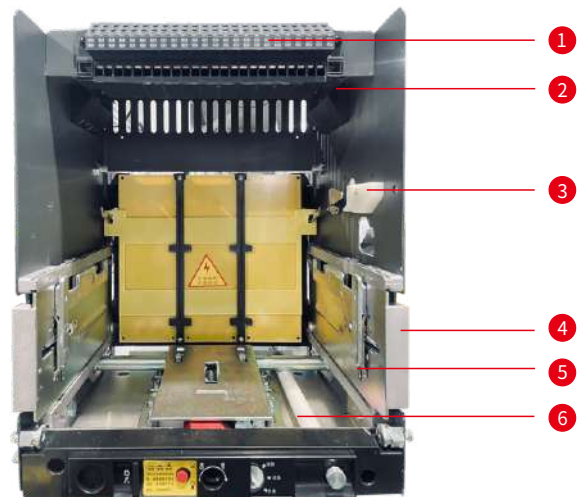

Figure 3. HUW9 series air circuit breaker cassette

- 1 Secondary wiring terminal(cassette part)
- 2 Handle
- 3 Adjusting support
- 4 Rail lock
- 5 Guide
- 6 Transmission shaft



HUW9 Air Circuit Breaker

Functions and Features

Product description



Features

6 Frame Size:1600,2000,2500,3200,4000,6300AF
Rated current In (A): 630 - 6300
Rated voltage AC Ue (V): Up to 690V
Poles: 3、 4
3 type of intelligent controllers
With “four remote” functions

Normal operating conditions

1、 Applicable temperature:

1.1 Ambient temperature is $-5^{\circ}\text{C} \sim +40^{\circ}\text{C}$ (certification);

1.2 the average value of 24h is no more than 35°C .

Note:

(1) when the temperature is more -10°C or -25°C , it should be noted;

(2) when the temperature is more than 40°C or less than -25°C , it should be noted;

2、 Altitude: $\leq 2,000\text{m}$ at the mounting site;

3、 Atmospheric conditions:

- Air relative humidity: $\leq 50\%$ at the maximum temperature of $+40^{\circ}\text{C}$, and a higher relative humidity is allowed when at a lower temperature;

- For example, at 20°C , the humidity is 90%, and special measures should be taken for occasional condensation due to temperature change;

4、 Pollution level: Level 3;

5、 Mounting category:

Circuit breaker main circuit and under-voltage trip coil, power transformer primary coil are level IV, auxiliary circuit and control circuit is level III

6. Utilization category: B

7、 Installation condition: Installation position shall be vertical, inclination of each direction shall not more than 5° .

Classifications

1. By mounting method: Fixed type and withdrawable type

2. By operating mode: Motor operating and manual operating (for maintenance and repair)

3. By the number of poles: 3P and 4P

4. By release type: Intelligent controller, under-voltage instantaneous (or time delay) release, and shunt release

5. By intelligent over-current controller function: Mic5.0 (intelligent type), Mic2.0 (multi-function type); Mic1.0 (standard type).

HUW9 Air Circuit Breaker

Functions and Features

Product selection

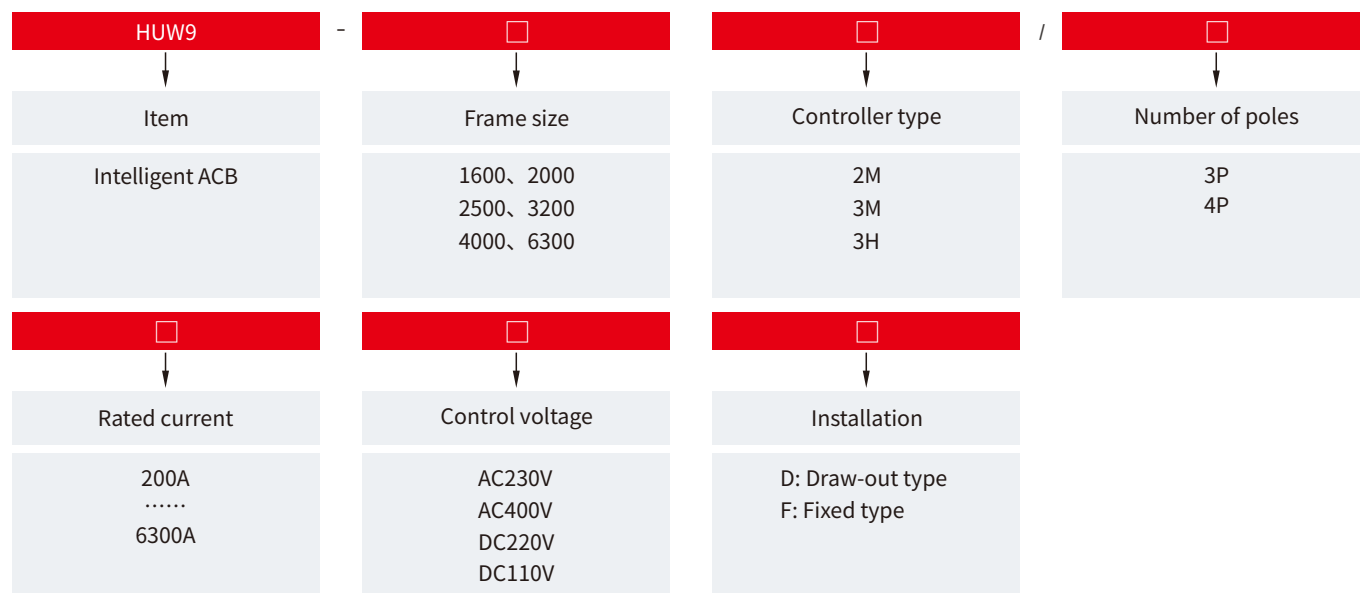

Technical data

Table 2

Frame size(Inm)	HUW9-1600		HUW9-2000		HUW9-2500		
Rated operating In(A)	200、400、630、800、1000、1250、1600		630、800、1000、1250、1600、2000		2500		
Neutral pole rated current In(A)	100%In		100%In		100%In		
Rated operated voltage Ue(V)	AC400、AC690						
Rated frequency (Hz)	50/60Hz						
Number of poles	3P/4P						
Rated impulse withstand voltage Uimp(kV)	AC12						
Rated insulation Voltage Ui(V)	AC1000						
Power frequency withstand voltage(V)	AC3500						
Rated short-circuit breaking capacity Icu (kA)	AC400V	50		85		85	
	AC690V	35		50		50	
Operating short-circuit breaking capacity Ics(kA)	AC400V	42		65		65	
	AC690V	35		50		50	
Rated short-time withstand current Icw/1s (kA)	AC400V	42		65		65	
	AC690V	35		187		187	
Rated short-circuit making capacity Icm (kA)	AC400V	110		50		50	
	AC690V	73.5		110		110	
Utilization category	B						
Breaking time	≤30ms						
Marking time	≤70ms						
Service life (times) ≤2500 1time/3min >2500 1time/6min	AC400VElectrical life	5000		4500		4000	
	without maintenance	10000		10000		8000	
	with maintenance	20000		20000		20000	
Drawer seat mechanical life 1 time /2min	1000			1000		1000	
Incoming method	Top or bottom enter						
Flashover distance(mm)	0						
Installation method	Fixed type	Draw-out type		Fixed type	Draw-out type		
	Fixed type	Draw-out type	Fixed type	Draw-out type	Fixed type	Draw-out type	
	Fixed type	Draw-out type	Fixed type	Draw-out type	Fixed type	Draw-out type	
	Fixed type	Draw-out type	Fixed type	Draw-out type	Fixed type	Draw-out type	
External dimensions(mm)	a	339(4P)/269 (3P)	372(4P)/302 (3P)	457(4P)/362 (3P)	500(4P)/405 (3P)	457(4P)/362 (3P)	500(4P)/405 (3P)
	b	327	357	402	432	402	432
	c	235.5	337	338	457	338	457

HUW9 Air Circuit Breaker

Functions and Features

Table 2

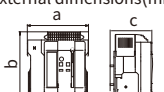
Frame size(Inm)	HUW9-3200		HUW9-4000		HUW9-6300	
Rated operating In(A)	2000、2500、3200		4000		4000、5000、6300	
Neutral pole rated current In(A)	100%In		100%In		50%In	
Rated operated voltage Ue(V)	AC400、AC690					
Rated frequency (Hz)	50/60Hz					
Number of poles	3P/4P					
Rated impulse withstand voltage Uimp(kV)	AC12					
Rated insulation Voltage Ui(V)	AC1000					
Power frequency withstand voltage(V)	AC3500					
Rated short-circuit breaking capacity Icu (kA)	AC400V	85	85	85	120	
	AC690V	65	65	65	85	
Operating short-circuit breaking capacity Ics(kA)	AC400V	70	70	70	100	
	AC690V	65	65	65	85	
Rated short-time withstand current Icw/1s (kA)	AC400V	70	70	70	100	
	AC690V	187	187	187	264	
Rated short-circuit making capacity Icm (kA)	AC400V	65	65	65	85	
	AC690V	143	143	143	187	
Utilization category	B					
Breaking time	≤30ms					
Marking time	≤70ms					
Service life (times) ≤2500 1time/3min >2500 1time/6min	AC400VElectrical life without maintenance	4000	3000	3000	2000	
	with maintenance	8000	8000	8000	5000	
Drawer seat mechanical life 1 time/2min		600	600	600	300	
Incomming method	Top or bottom enter					
Flashover distance(mm)	0					
Installation method	Fixed type	Draw-out type	Fixed type	Draw-out type	Draw-out type	
External dimensions(mm) 	a	537(4P)/422 (3P)	579(4P)/464 (3P)	537(4P)/422 (3P)	579(4P)/464 (3P)	927(4P)/927 (3P)
	b	402	432	402	432	432
	c	338	493	338	493	497

HUW9 Air Circuit Breaker

Functions and Features

Controller panel structure

Table 3

Controller function		2M	3M	3H	
Standard functions	Overload protection	■	■	■	
	Short-circuit protection with short delay	■	■	■	
	Short-circuit protection instantaneous	■	■	■	
	Ground protection choose either	Differential type	■	■	■
		Ground current type	□	□	□
	Earth leakage protection(choose either grounding protection or Earth leakage protection)		—	□	□
	Overload warning	—	□	□	
	Current unbalance protection/Phase loss protection	□	□	□	
	Current demand value protection	—	□	□	
	Over-voltage protection	—	□	□	
	Under-voltage protection	—	□	□	
	Voltage unbalance protection	—	□	□	
	Over-frequency protection	—	□	□	
	Under-frequency protection	—	□	□	
	Phase sequence protection	—	□	□	
	Reverse power protection	—	□	□	
	Over-temperature protection and alarm	—	□	□	
	Thermal memory protection	■	■	■	
	Load monitoring	—	□	□	
	Zone interlock (ZSI) function	—	□	□	
	MCR protection	□	□	□	
	HSISC protection	□	□	□	
	Remote reset	—	□	□	
	Current measurement	■	■	■	
	Voltage measurement	—	□	■	
	Power measurement	—	□	□	
	Power factor measurement	—	□	□	
	Frequency measurement	—	□	□	
	Energy measurement	—	—	□	
	Harmonic measurement	—	—	□	
Thermal capacity measurement	—	□	□		
Phase sequence measurement	—	□	□		
Demand measurement (current)	—	□	□		
Demand measurement (power)	—	□	□		
Contact wear equivalent measurement	—	■	■		
Temperature measurement	—	□	□		
Measurement function	LED fault status display	■	■	■	
	Fault recording and query	■	■	■	
	Historical current peak record	—	□	□	
	Alarm history record query	—	□	□	
	Fault trip signal output	■	■	■	
	Self-diagnosis function	■	■	■	
	Simulated trip test function	■	■	■	
	Number of operations query	—	□	□	
Other optional functions	Clock function	—	□	□	
	I/O setting function	—	□	□	
	Password setting function	—	■	■	
Contact output	External transformer function	□	□	□	
	Programmable contact output	—	□	□	
	Auxiliary contact output	■	■	■	
Communication function	Alarm signal output	■	■	■	
	Based on RS485, standard Modbus protocol, other protocols can be customized	—	—	■	

HUW9 Air Circuit Breaker

Functions and Features

2M: Digital display

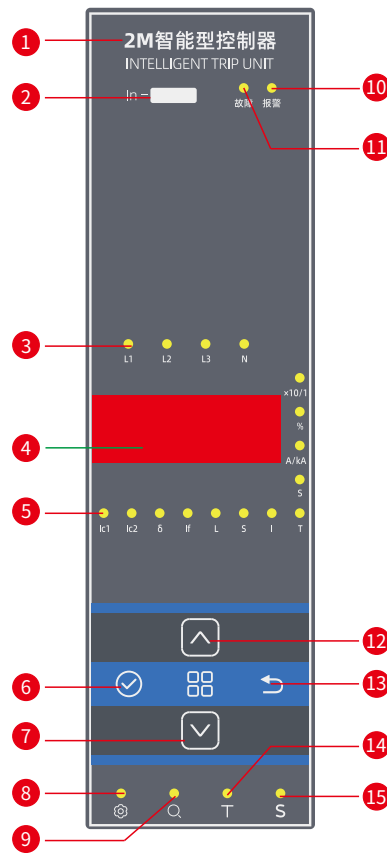

2M: Digital display

- | | |
|---|--|
| <p>1 In: Rated current</p> <p>2 Fault lamp</p> <p>3 L1, L2, L3 and N indicators
N phase Current
A phase Current
B phase Current
C phase Current</p> <p>4 Digital display window--
display the current value
voltage value
rated frequency
the setting parameter
the fault current
and other parameters</p> <p>5 Parameter indicator--
Ic1: Load monitoring 1;
Ic2: Load monitoring 2;
δ: Current unbalance protection;
If: Ground protection;
L: Long delay protection;
S: Short delay protection;
I: Instantaneous protection
T: Self-diagnosis by the intelligent controller;</p> | <p>5 10/1 : the number of circuit breaker actions;
% : percentage of contact wear;
A/kA : Ampere/kla) (current);
S: time</p> <p>6 Enter key</p> <p>7 -/ down page</p> <p>8 Set key</p> <p>9 "Query" Indication</p> <p>10 Alarm lamp</p> <p>11 Fault lamp</p> <p>12 +/- up page</p> <p>13 Return key: back to the previous level or resetting</p> <p>14 Test: tripping indication</p> <p>15 Store indicator: Indicating that a data change has occurred</p> |
|---|--|

HUW9 Air Circuit Breaker

Functions and Features

3M type (LCD display)

3H type (communication)

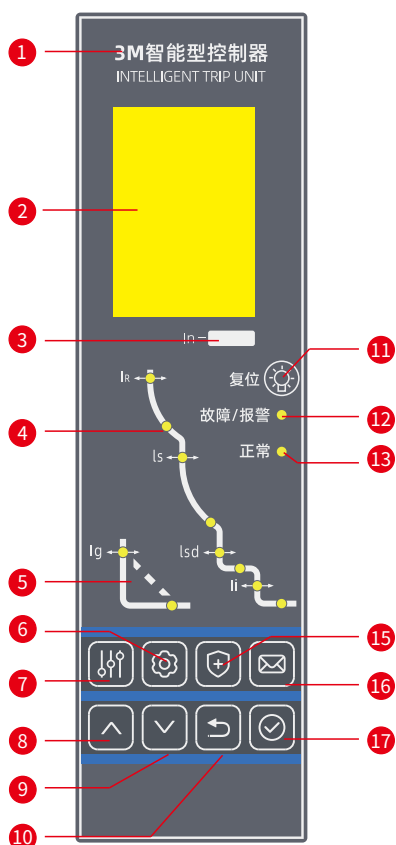

3M type (LCD display)

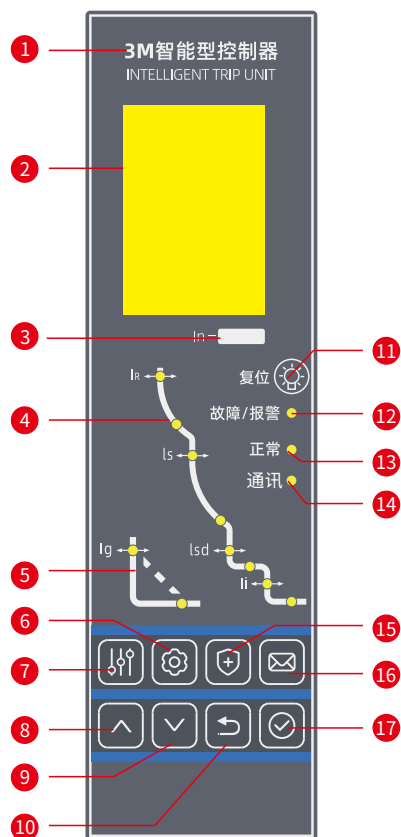

3H type (communication)

- 1 Reset button
- 2 LCD display window-
- 3 In Rated current
- 4 Overload protection, short circuit protection
- 5 Ground protection
- 6 Set key
- 7 Running key
- 8 +/- up page
- 9 -/ down page
- 10 Return key

- 11 Reset key
- 12 Alarm lamp/Fault lamp
- 13 "Normal" indicator
- 14 Communication function Indication
- 15 Protection setting key
- 16 Query key
- 17 Enter key

Note: Due to rapid upgrade of intelligent controllers, the actual controller type shall prevail, not limited to the above-mentioned controller types. Relevant functions can be tailor-made to your requests.

HUW9 Air Circuit Breaker

Functions and Features

2、 Intelligent overcurrent controller protection characteristics and functions

2.1 The protection characteristics of the intelligent controller are shown in Fig. 1 to Fig. 4.

Figure 1, Basic functions (long time delay short time delay and transient protection)

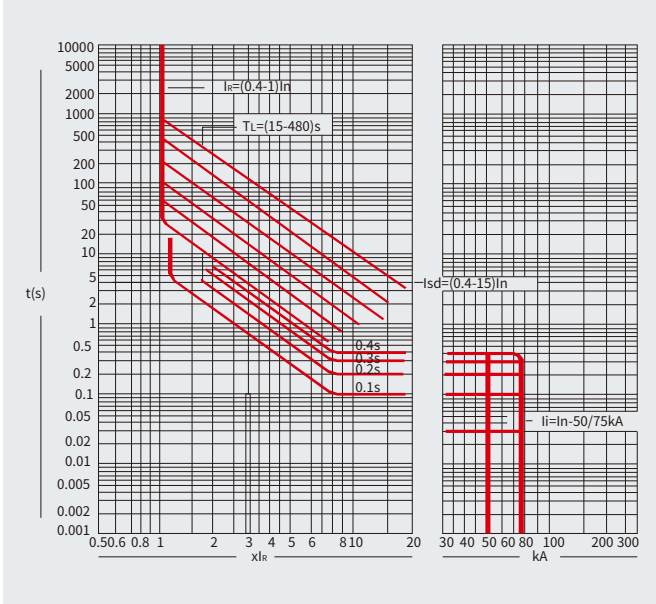

Figure 2. Ground fault protection

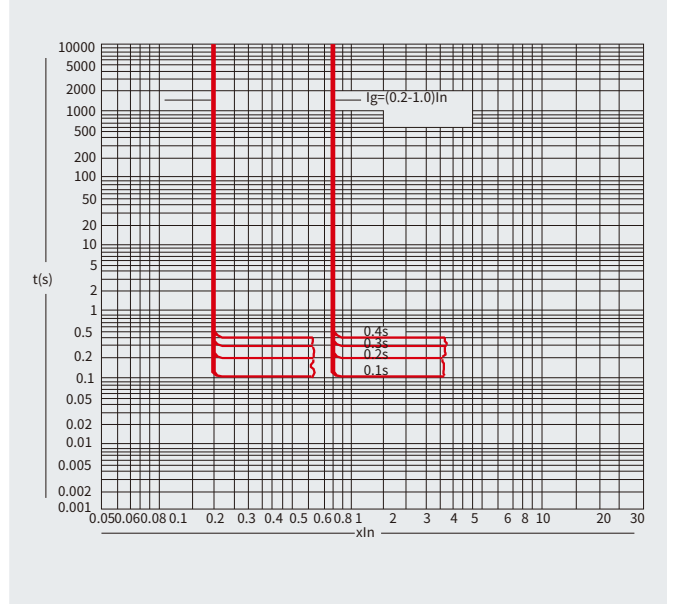

Figure 3. Load monitoring and control (1 load limiting and 1 load coincidence protection characteristics)

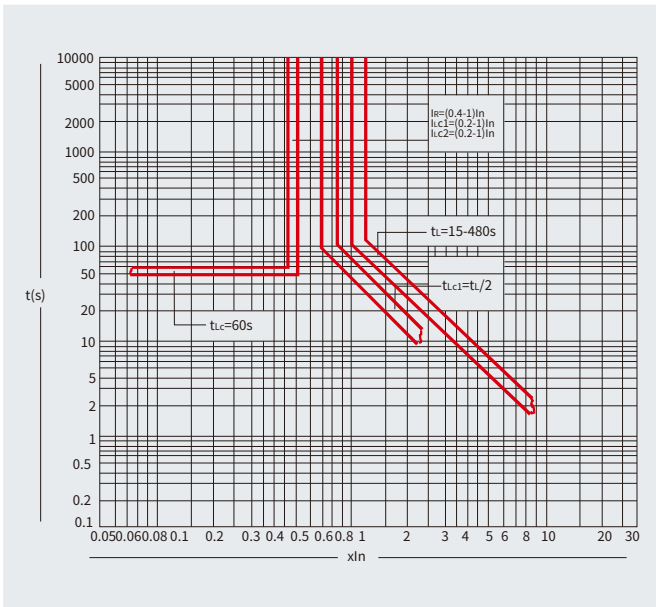
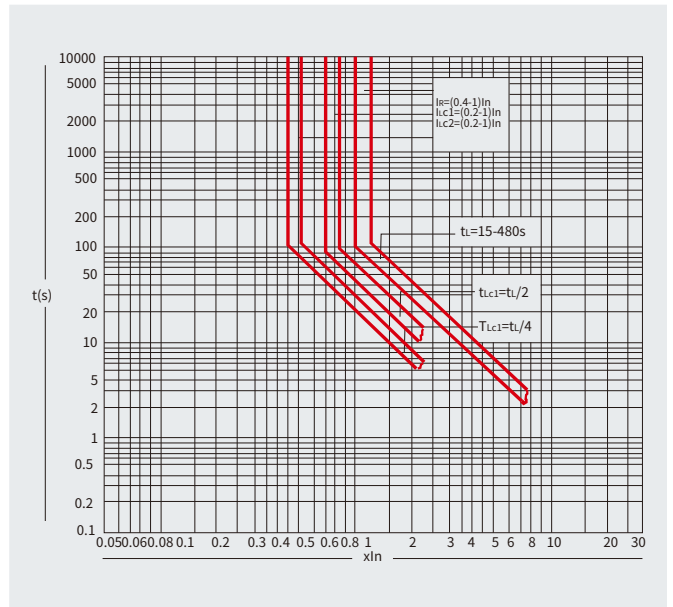

Figure 4. Load monitoring and control (protection characteristics with double load limiting)



3.1.1 Current setting value I_r of the trip coil and tolerance

Table 4

Long delay		Short delay		Instantaneous		Ground fault	
I_r	Tolerance	I_{sd}	Tolerance	I_i	Tolerance	I_g	Tolerance
$(0.4\sim 1)I_n$	$\pm 10\%$	$(0.4\sim 15)I_n$	$\pm 10\%$	$1.0I_n\sim 75kA$	$\pm 15\%$	$(0.2\sim 1.0)I_n$	$\pm 10\%$

注：当同时具有三段保护时，整定值不能交叉，且 $I_r < I_{sd} < I_i$ 。

HUW9 Air Circuit Breaker

Functions and Features

Function description

- Major protection functions (controller's functions are set to requirements upon factory delivery; please contact us for resetting)

Includes long delay over-load protection, short-circuit short-time fixed time and inverse time protection, short-circuit instantaneous protection, grounding or residual current fixed time and inverse time protection, N-phase protection, current unbalance protection due to phase loss, and load inverse time monitoring.

- Measurement and operation monitoring

Real-time measurement of various power grid operating parameters, such as frequency, power factor, active power, etc.; real-time indication of operating status, such as, fault status, alarm status, system self-diagnosis status, normal operation status, and etc.

- Query function

Operation parameter query, protection parameter setting query, historical fault record query, self-diagnosis fault information query and power grid measurement parameter query

- Parameter setting function

The following protection parameters can be directly set on the controller panel: overload long delay protection's current and time, short circuit short delay protection's inverse time current and fixed time current and time, instantaneous protection's current, load monitoring's current and time, N-phase protection settings, grounding or residual current protection's current and time and inverse time coefficient, current unbalance protection's unbalance rate and time, and harmonics Influence factor.

The following operations can also be performed on the controller panel: system clock adjustment (only available after selected), and setting all internal system parameters that can be set by the programmer (programmer is not required, but authorization password is required).

- Programming interface function

An interface with the programmer is available, to modify some specific parameters, such as, signal output contact's function setting, voltage measurement's wiring method, system clock, protection characteristic curve, thermal memory function, communication address, communication baud rate, and etc.

Communication network function (only available for Mic5.0 intelligent controller) The controller provides a standard RS485 interface and ensures data transmission through Modbus or Profibus-DP or DeviceNet protocols, to meet the "four remote" requirements in different monitoring systems.

- Test function

The test function offers two types: instantaneous tripping simulation test and non-tripping simulation test:

(1) Instantaneous tripping simulation test: Instantaneous tripping test can be performed on the circuit breaker, with the action time

(2) inherent to the circuit breaker to be displayed after the action time.

(3) Non-tripping simulation test: Select simulation test current for the system's non-tripping test. Test current, system delay action time

(4) under the test current, and fault category of the simulation test will be displayed in turn after the test is completed.

- Self-diagnosis function

Diagnose and alarm when faults occur in the controller itself.

- Fault clock function (optional)

Record the time when the fault occurs Th, including the year, month, day, hour, minute and second when the fault occurs, with up to 8 records.

- Historical data recording function (optional)

Record four-phase current, three-phase voltage, frequency, power, power factor, and active power, every half an hour, for three months.

Load monitoring protection function

Load monitoring is to control different loads of the circuit breaker to ensure the power supply to the main loads as much as possible. Load monitoring can be used for pre-alarming and branch load control. The controller can be programmed to output two passive signal contacts for load monitoring.

- MCR ON-OFF and over-limit trip function (optional)

ON-OFF means that the power grid is already in a fault state before the circuit breaker is closed, a current greater than MCR set value is generated upon closing, and the controller opens the circuit breaker instantaneously through an analog circuit. This function only works at the moment of closing (within 100ms).

Over-limit tripping means that when the circuit breaker is in normal operation, if the short-circuit current exceeds a certain value (usually the ultimate current of the circuit breaker), the controller will instantaneously break the circuit breaker through an analog circuit. This function is not subject to instantaneous settings.

- Communication protocol

Includes an internal Modbus-RTU, and can be transferred to Profibus-DP or DeviceNet through an external module.

HUW9 Air Circuit Breaker

Functions and Features

Installation and wiring

Outline and mounting dimensions of HUW9-1600 fixed type circuit breakers

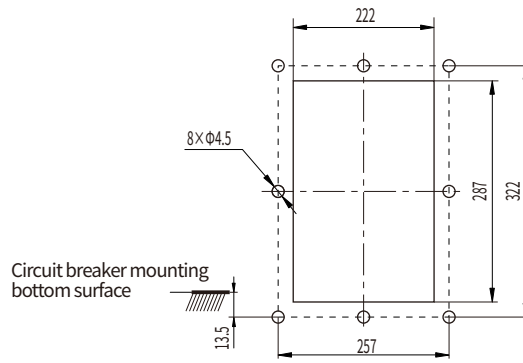
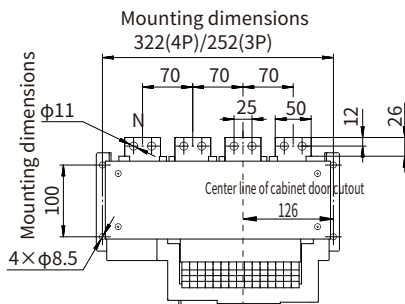
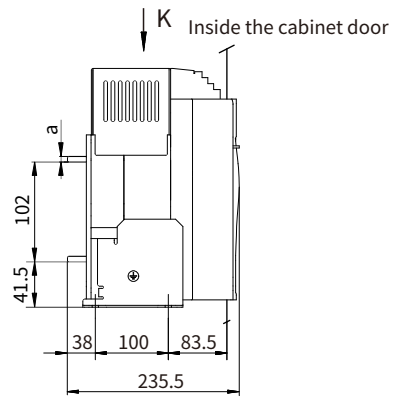
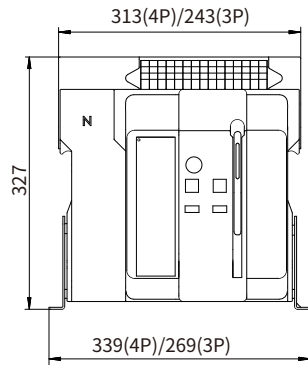

K direction Horizontal wiring and mounting dimensions

Cabinet door hole size

In (A)	a(mm)
≤1000	10
≥1250	15

HUW9 Air Circuit Breaker

Functions and Features

Outline and mounting dimensions of HUW9-1600 draw-out type circuit breakers
(choose either inner or outer mounting dimensions for fastening)

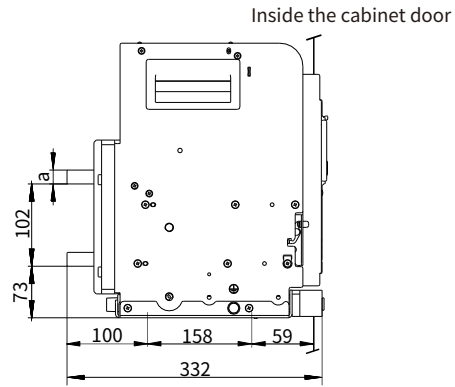
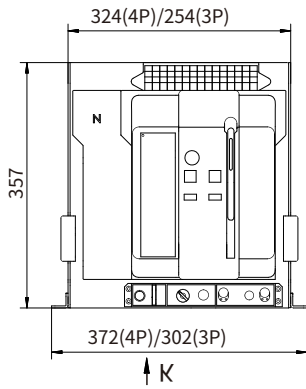

Horizontal connection dimensions

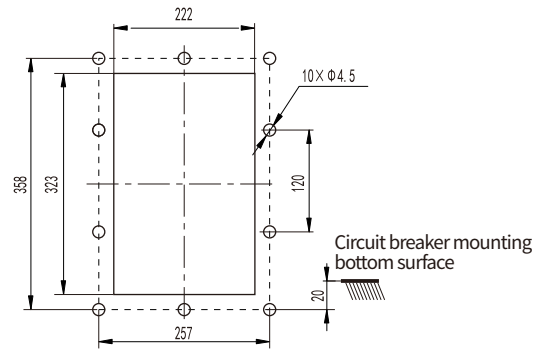
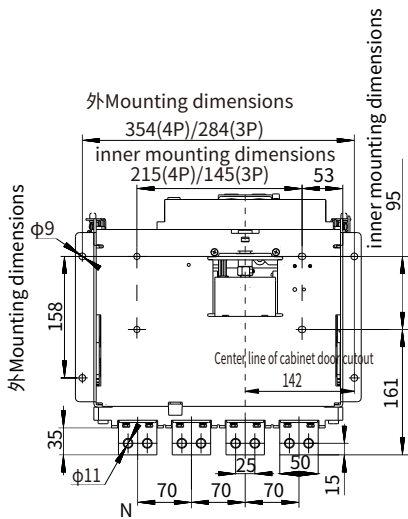

Cabinet door cutout dimensions for HUW9-1600 draw-out type

In (A)	a(mm)
≤1000	10
≥1250	15

HUW9 Air Circuit Breaker

Functions and Features

Outline and mounting dimensions of HUW9-2000 and HUW9-2500 fixed type circuit breaker

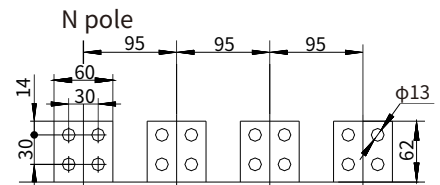
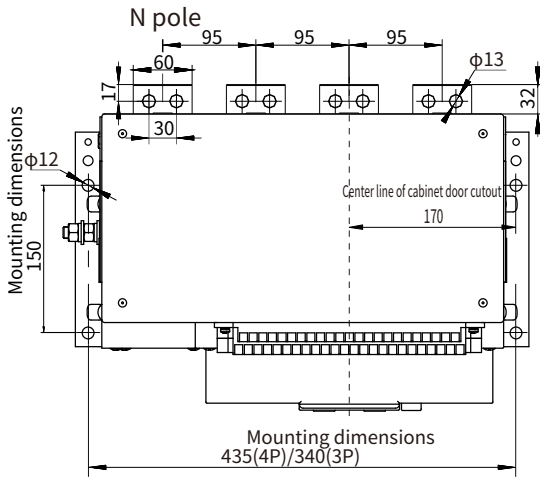
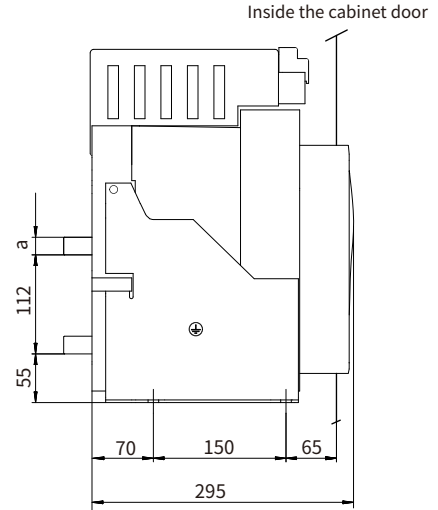
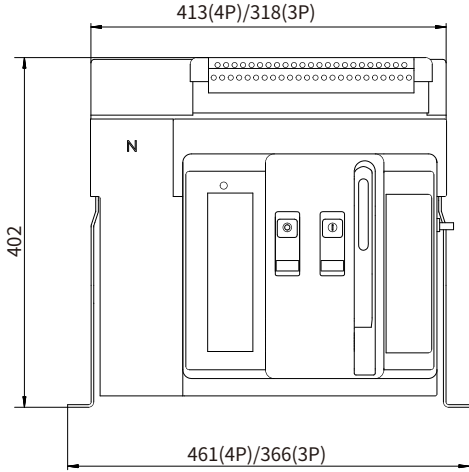

Inm=2000A Extended busbar

Inm=2500A Horizontal connection dimensions

Inm=2000A Horizontal wiring and mounting dimensions

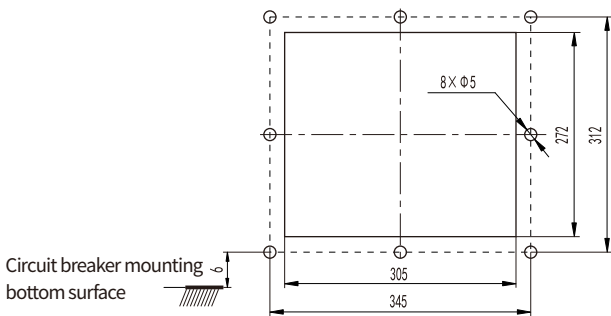

Cabinet door cutout dimensions for HUW9-1600 fixed type

In (A)	a(mm)
630、800	10
1000、1250、1600	15
2000、2500	20

HUW9 Air Circuit Breaker

Functions and Features

Outline and mounting dimensions of HUW9-2000 and HUW9-2500 draw-out type circuit breakers
(choose either inner or outer mounting dimensions for fastening)

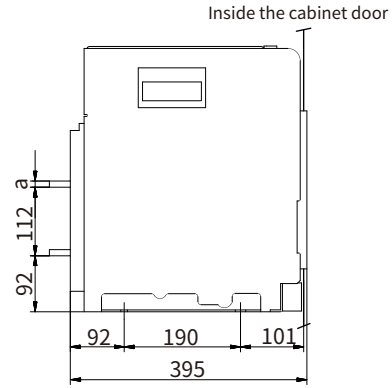
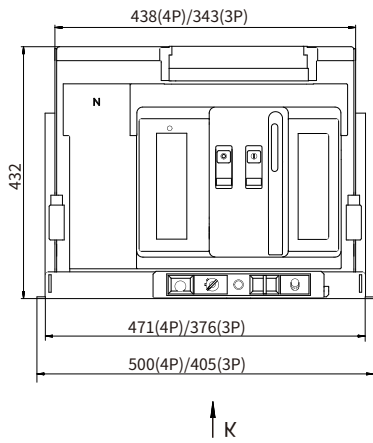

Horizontal wiring and mounting dimensions

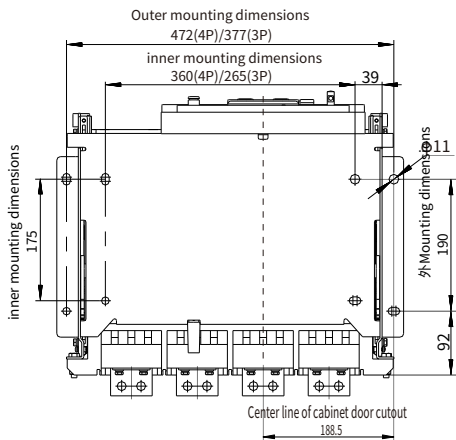

K direction Horizontal wiring and mounting dimensions

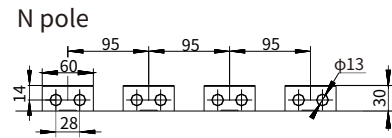

Inm=2000A Horizontal connection dimensions

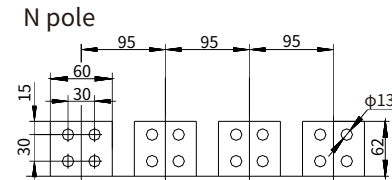

Inm=2000A Extended busbar Horizontal connection dimensions

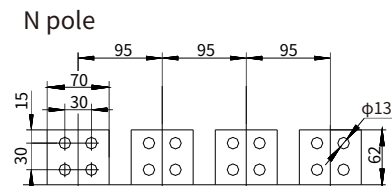

Inm=2500A Horizontal connection dimensions

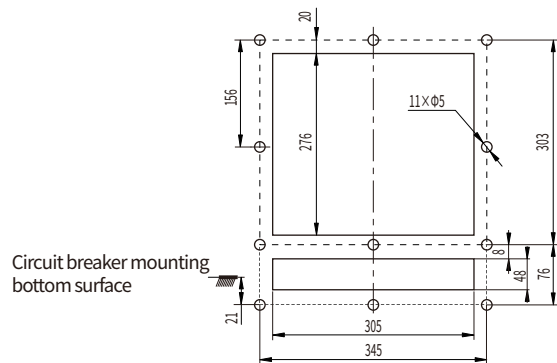

Cabinet door cutout dimensions for HUW9-1600 draw-out type

In (A)	a(mm)
630、800	10
1000、1250、1600	15
2000、2500	20

HUW9 Air Circuit Breaker

Functions and Features

Outline and mounting dimensions of HUW9-3200 and HUW9-4000 fixed type circuit breakers

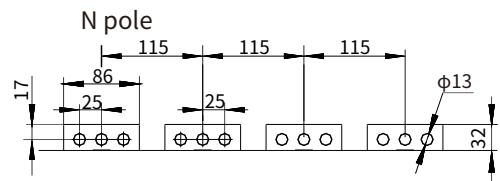
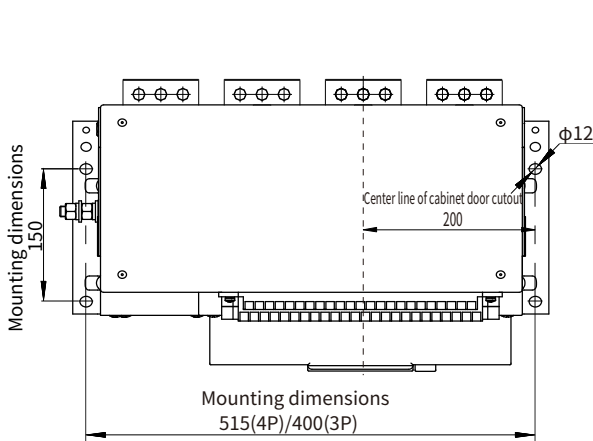
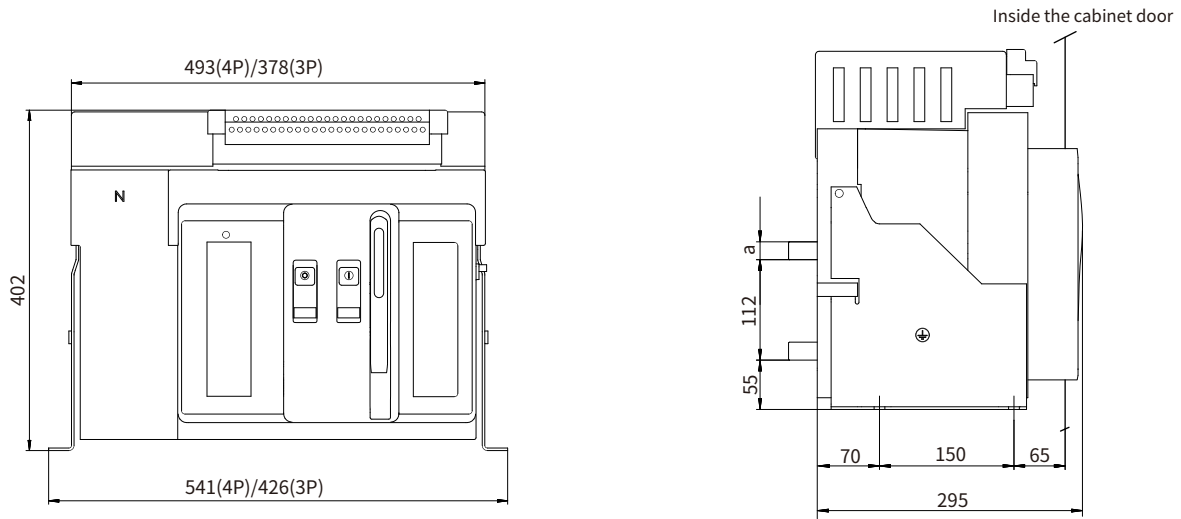

Inm=3200A Horizontal connection dimensions

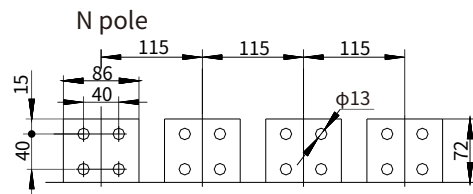

Inm=3200A Extended busbar

Inm=4000A Horizontal connection dimensions

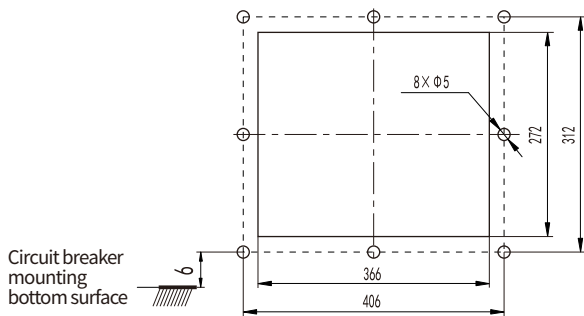

In (A)	a(mm)
2000、2500	20
3200、4000	30

Cabinet door cutout dimensions for HUW9-1600 fixed type

HUW9 Air Circuit Breaker

Functions and Features

Outline and mounting dimensions of UW9320 and UW9400 raw-outtype circuit breakers
(choose either inner or outer mounting dimensions for fastening)

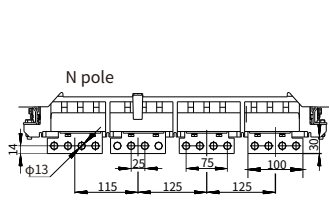
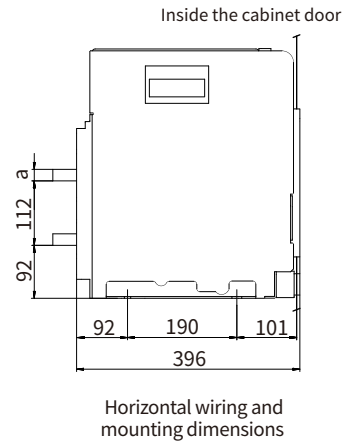
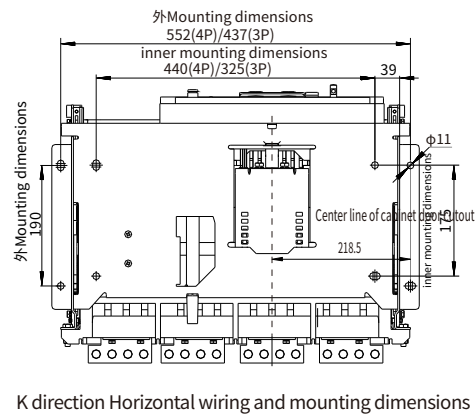
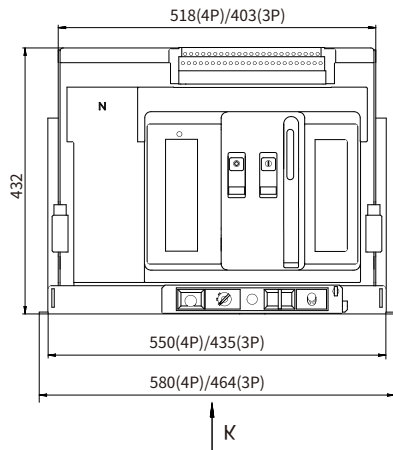

Inm=3200A Horizontal connection dimensions

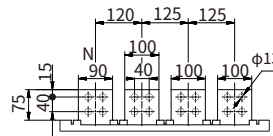
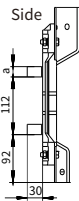

Inm=3200 Extended busbar Horizontal connection dimensions

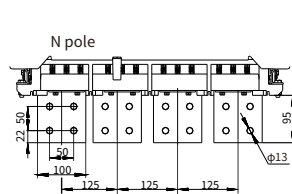
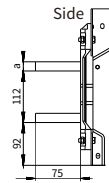

Inm=4000A Horizontal connection dimensions

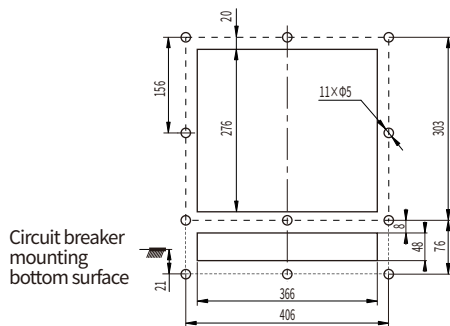
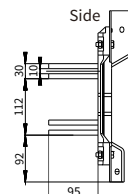

Cabinet door cutout dimensions for HUW9-1600 draw-out type

In (A)	a(mm)
2000、2500	20
3200、4000	30

HUW9 Air Circuit Breaker

Functions and Features

Outline and mounting dimensions of HUW9-6300 withdrawable type circuit breakers
(choose either inner or outer mounting dimensions for fastening)

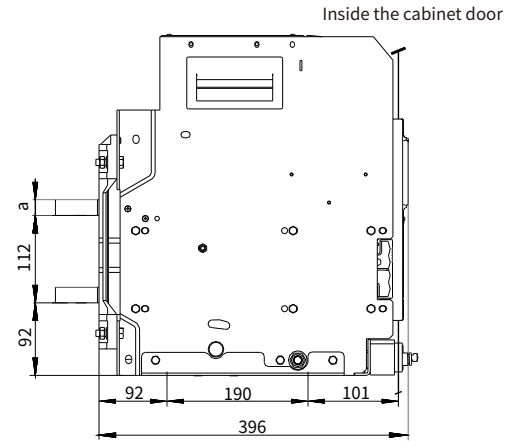
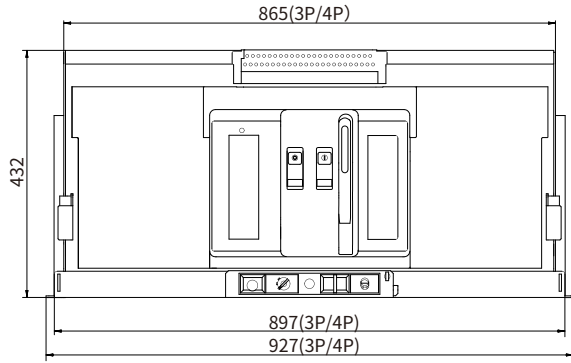

Horizontal connection dimensions

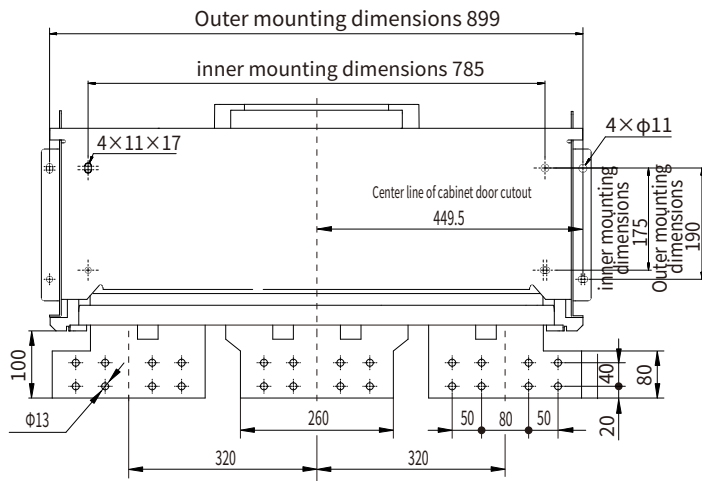

3P Horizontal wiring and mounting dimensions

In(A)	a(mm)
4000、5000	20
6300	30

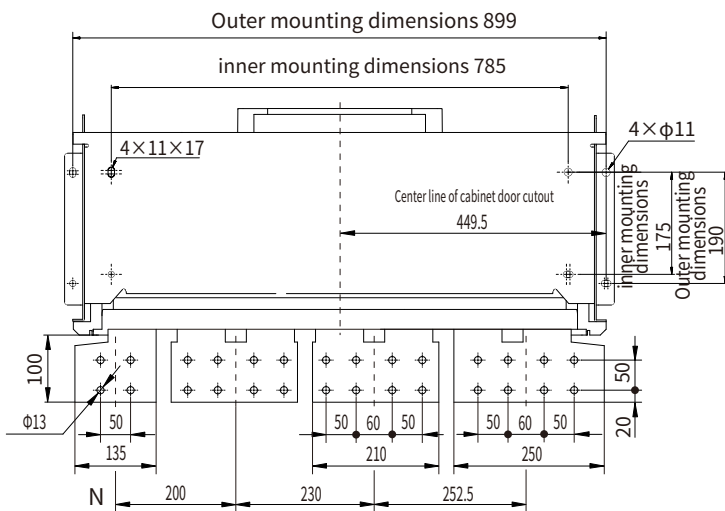

4P Horizontal wiring and mounting dimensions

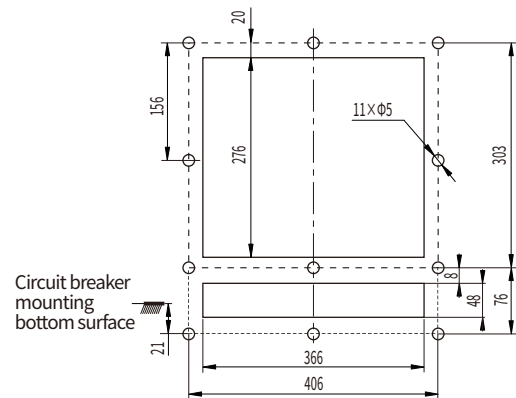

Cabinet door cutout dimensions for HUW9-1600 draw-out type

HUW9 Air Circuit Breaker

Functions and Features

Secondary circuit wiring diagram

- 1) The wirings for the dashed lines should be made by the user himself. If optional accessories are not ordered for customization, the wirings cannot be made for the dashed lines.
- 2) If the voltages to the accessories, such as, intelligent controllers, undervoltage releases, shunt releases, closing electromagnets, motor operators, are different, different power sources should be connected to them.
- 3) The undervoltage release is directly connected to the incoming terminal of the main circuit, with the maximum working voltage not exceeding its rated working voltage. When the working voltage in the main circuit is higher than its rated working voltage, a transformer is needed to drop the working voltage down to its rated working voltage before put into use;
- 4) The cassette three-position indication function is only available for withdrawable circuit breakers.
- 5) With DC as the working power of the intelligent controller, first connect the ST power module (optional) and then connect the intelligent controller #1 and #2.

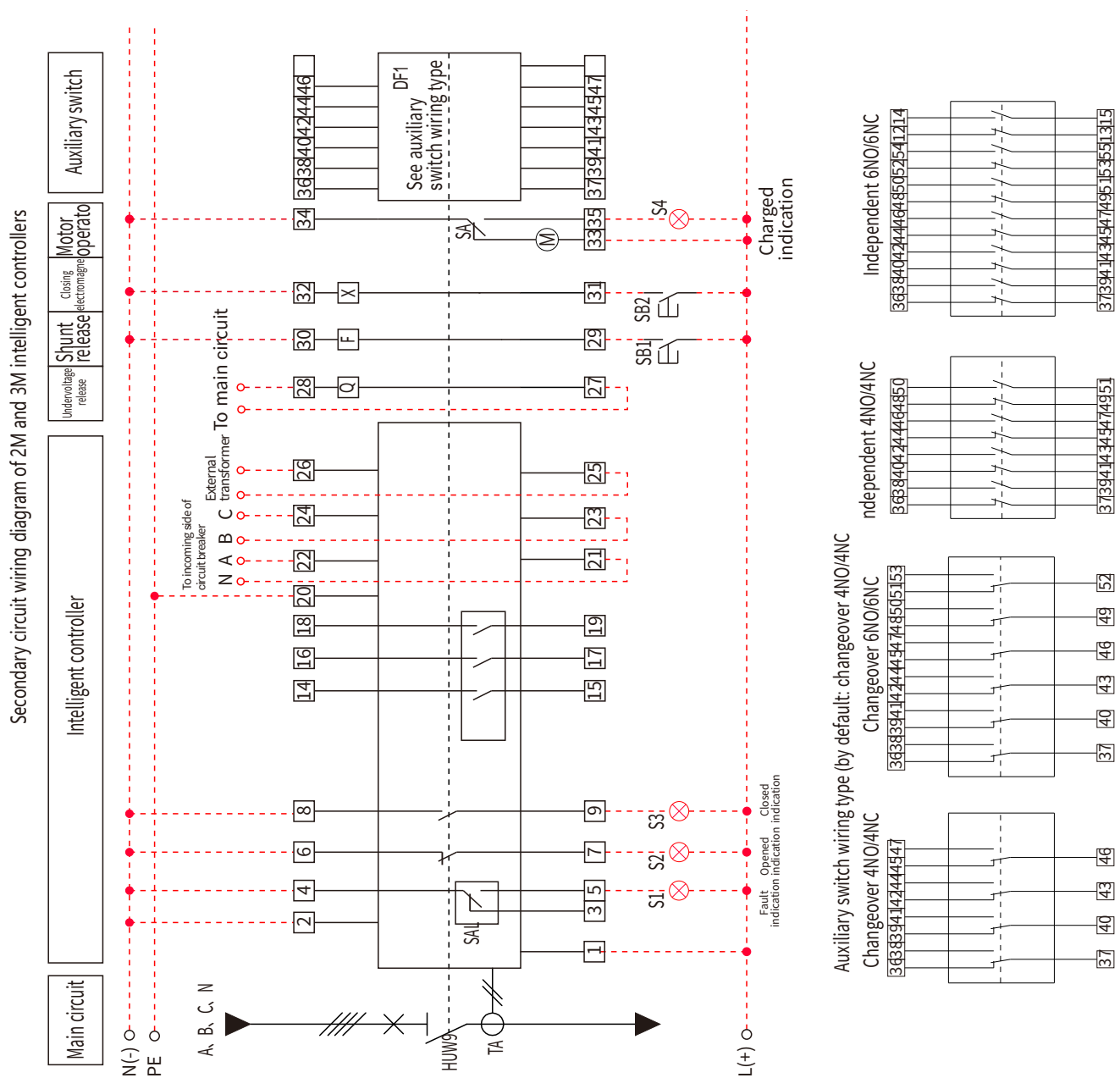

HUW9 Air Circuit Breaker

Functions and Features

Secondary circuit wiring diagram terminal functions of 2M and 3M intelligent controllers

Terminal No.	Function description	Note
1、 2	Auxiliary power input: AC230V, AC400V, DC220V, DC110V	
3、 4、 5	Fault tripping auxiliary contact and contact capacity: AC250V, 3A	
6、 7	Circuit breaker status auxiliary contact (NC) and contact capacity: AC250V, 3A	
8、 9	Circuit breaker status auxiliary contact (NO) and contact capacity: AC250V, 3A	
20	Ground (PE)	
21、 22、 23、 24	Voltage signal measurement: 21 to N, 22 to A, 23 to B, 24 to C	Optional function
25、 26	External transformer input terminal (earth leakage transformer, neutral line transformer, ground current transformer)	Optional function and accessory
27、 28	Undervoltage release	Optional accessory
29、 30	Shunt release	
31、 32	Closing electromagnet	
33、 34、 35	Motor operator	
36~.....	DF1 auxiliary switch wiring terminal	

Secondary circuit wiring diagram terminal functions of Mic5.0 intelligent controllers

Terminal No.	Function description	Note
1、 2	Auxiliary power input: AC230V, AC400V, DC220V, DC110V	
3、 4、 5	Fault trip auxiliary contact and contact capacity: AC250V, 3A	
6、 7	Circuit breaker status auxiliary contact (NC) and contact capacity: AC250V, 3A	
8、 9	Circuit breaker status auxiliary contact (NO) and contact capacity: AC250V, 3A	
10、 11	Communication interface output, 10 connected to A, 11 connected to B	Modbus protocol by default
12~19	Signal input and output, 12 and 13 are DO1; 14, 15 are DO2; 16, 17 are DO3; 18, 19 are DO4	Set to functional requirements
20	Ground (PE)	
21、 22、 23、 24	Voltage signal measurement: 21 to N, 22 to A, 23 to B, 24 to C	
25、 26	External transformer input (earth leakage transformer, neutral line transformer, ground current transformer)	
27、 28	Undervoltage release	
29、 30	Shunt release	Optional accessory
31、 32	Closing electromagnet	
33、 34、 35	Motor operator	
36~.....	DF1 auxiliary switch wiring terminal	

HUW9 Air Circuit Breaker

Functions and Features

Wiring diagram symbol description

Symbol	c	Note	Symbol	Description	Note
HUW9	HUW9series universal circuit breaker		PE	Ground wire	
S1~S7	Signal light	User-supplied	L(+), N(-)	Control power supply (For DC, L is positive and N is negative)	
TA	Current transformer		A, B, C, N	Main circuit' s phase line	
SAL	Micro switch		Df1	Auxiliary switch	Type can be selected
SB1	Opening button	User-supplied	DF2	Cassette three-position electrical indication switch	Optional accessory
SB2	Closing button	User-supplied	ST power module	DC 24V power supply is available	Optional accessory
X	Closing electromagnet		St201	Relay module	Optional accessory
F	Shunt release	Optional accessory	Protocol converter	Except the Modbus protocol, other protocols need to be configured	Optional accessory
Q	Undervoltage release				
M	Motor operator				
SA	Motor operator' s limit switch				

HUW9 Air Circuit Breaker

Functions and Features

Accessory functions and features

1600A frame closing electromagnet



● Closing electromagnet

When the circuit breaker is fully charged and in the normal opened state, the closing electromagnet can be used to remotely control the quick closing of the circuit breaker

Working voltage U_s	AC230	AC400	DC220V	DC110V
Working voltage range	(85~110)% U_s			
Starting current	1.3A	0.7A	1.3A	2.5A
Circuit breaker response time	$\leq 60\text{ms}$			

2000A frame and above closing electromagnet



1600A frame shunt release



● Shunt release

When the circuit breaker is in the closed state, the shunt release can be used to remotely control the quick opening of the circuit breaker

Working voltage U_s	AC230	AC400	DC220V	DC110V
Working voltage range	(70~110)% U_s			
Starting current	1.3A	0.7A	1.3A	2.5A
Circuit breaker response time	$\leq 30\text{ms}$			

2000A frame and above shunt release



● Undervoltage release

The circuit breaker cannot be closed when the undervoltage release is not powered; for 2500A frame and above, two types are available for the undervoltage release: Assisted-drawn (without delay function) and self-drawn;

1600A frame undervoltage release



Working voltage U_e	AC230	AC400
Opening voltage range	(35~70)% U_e	
Reliable closing voltage range	(85~110)% U_e	
No-closing voltage range	$\leq 35\%U_e$	
Power loss	20VA	
Delay tripping time	Instantaneous, 0.5s, 1s, 3s, 5s	

2000A frame and above undervoltage release



Note 1: Within 1/2 of the delay tripping time, the circuit breaker cannot be opened when the working voltage recovers to more than 85% of U_e ;

Note 2: In areas prone to lightning and power grids with unstable power supply voltage, it is recommended to use the undervoltage release with time delay, to prevent the circuit breaker from opening due to short time voltage drop;

Note 3: Maximum delay time for the undervoltage delay tripping time is 10s, and maximum delay time for the zero-voltage delay tripping time is 5s (consult with the manufacturer upon ordering).

HUW9 Air Circuit Breaker

Functions and Features

Inter-phase partition



● Inter-phase partition

The inter-phase partition is vertically mounted between the wiring busbars of each phase of the circuit breaker, to enhance the insulation capacity of the circuit breaker between phases

1600A frame charging motor



● Charging motor

The charging motor enables the circuit breaker to be charged electrically. Automatic charging operation will be conducted after the circuit breaker is closed, allowing the circuit breaker to be closed again right after it is opened.

2000A frame and above charging motor



Working voltage U_s	AC230	AC400	DC220V	DC110V
Working voltage range	(85~110)% U_s			
Charging time	$\leq 7s$ (Cyclical period: ≤ 1 time/min)			
1600 frame power loss	75VA		75W	
2000/2500 frame power loss	85VA		85W	
3200/4000 frame power loss	110VA		110W	
6300 frame power loss	150VA		150W	

Note: Manual charging operation can also be performed during the maintenance of the circuit breaker.

1600A frame auxiliary switch

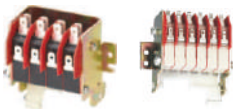

● Auxiliary switch

Type by default: Changeover 4NO/4NC

Other types: Independent 4NO/4NC, changeover 6NO/6NC, independent 6NO/6NC

2000A frame and above auxiliary switch



Rated working voltage	AC230	AC400	DC220V	DC110V
Conventional thermal current	6A			
Rated control capacity	300VA		60W	

Key lock



● Key lock

To unlock the circuit breaker: The key can be inserted to the lock when the gap on the key matches the red-dot position on the lock. Turn the key clockwise to the rightmost position, which is now in the unlocked state. At this time, the key cannot be pulled out directly, and the circuit breaker can be closed;

To lock the circuit breaker: First press the opening button of the circuit breaker, and then turn the key counterclockwise to the leftmost position to remove the key. At this time, the circuit breaker cannot be closed.

Note 1: The power supply modes listed below are only for reference. The interlock can be installed according to the actual power supply system needs on site. Or consult with the manufacturer. One lock and one key: A circuit breaker is equipped with one lock and one key, and the circuit breaker is not allowed to close when in the locked state

Note 1:

QF: HUW9 circuit breaker; 0: Circuit breaker is opened; 1: Circuit breaker is closed

Method 1: One power supply and one load
Circuit diagram Possible operation mode

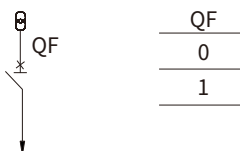

HUW9 Air Circuit Breaker

Functions and Features

Method 2: Two power supplies and one load interlock

Circuit diagram Possible operation mode

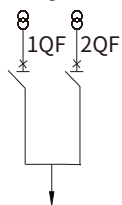

1QF	2QF
0	0
1	0
0	1

Two locks and one key: Two circuit breakers are equipped with two identical locks and one key, and only one circuit breaker is allowed to close

Method 3: Two power supplies and two load interlocks

Circuit diagram Possible operation mode

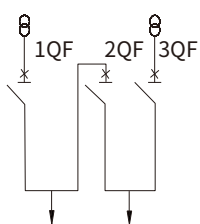

1QF	2QF	3QF
0	0	0
1	0	0
0	0	1
1	1	0
1	0	1
0	1	1

Three locks and two keys: Three circuit breakers are equipped with three identical locks and two keys, and only a maximum of two circuit breakers are allowed to close

Method 4: Three power supplies and one load interlock

Circuit diagram Possible operation mode

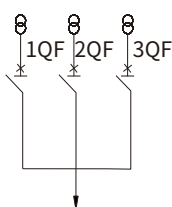

1QF	2QF	3QF
0	0	0
1	0	0
0	1	0
0	0	1

Three locks and one key: Three circuit breakers are equipped with three identical locks and one key, and only one circuit breaker is allowed to close



Escutcheon

■ Escutcheon + sealing ring

The escutcheon and sealing ring are mounted on the door of the power distribution cabinet where the circuit breaker is installed, to offer the sealing function and beautiful outlook, and feature IP 40 protection level.



Cassette operating padlock

■ Cassette operating padlock

When the basic device of the withdrawable circuit breaker is in the “Disconnected” position, pull out the clamping board and lock it with a padlock. After locking, the basic device cannot be racked into the “Test” or “Connected” position. (Padlock is supplied by users)



Relay module

■ Relay module

Input voltage: DC24V

Contact capacity: 10A/AC250V, 10A/DC28V.

A relay module is needed for conversion and control if the load capacity is large when controlling the opening and closing of the circuit breaker. A 35mm standard rail is used for mounting.

HUW9 Air Circuit Breaker

Functions and Features



Position-door interlock

■ Position-door interlock

The cabinet door is forbidden to open when the withdrawable circuit breaker's basic device is in the "Test" or "Connected" position. The cabinet door is allowed to open when the basic device is in the "Disconnected" position.



RCD zero-sequence current Transformer

■ RCD zero-sequence current transformer

An external zero-sequence current transformer is required when residual current type is used for the ground protection. The vector sum of each phase current is used as the signal sampling method, which is suitable for protecting smaller currents.

Mounting position schematic diagram of earth leakage protection transformers in different grounding systems

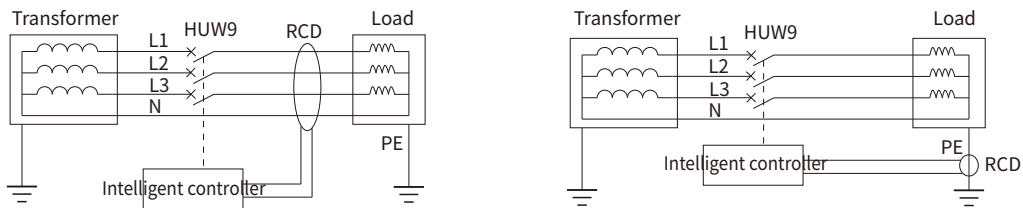

Mounting position schematic diagram of RCD transformer in TT systems

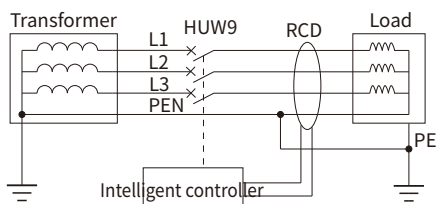

Mounting position schematic diagram of RCD transformer in TN-C-S systems

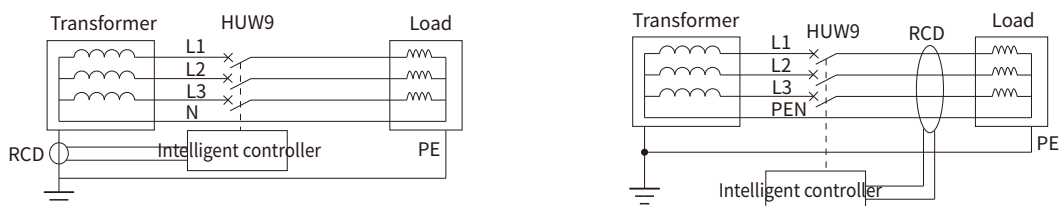

Mounting position schematic diagram of RCD transformer in TN-S systems

HUW9 Air Circuit Breaker

Functions and Features



Mechanical interlock

■ Mechanical interlock

Steel cable interlocking is used for two circuit breakers placed side by side, or connecting rod interlocking is used for two circuit breakers placed in stack.

Steel cable interlocking or connecting rod interlocking of two circuit breakers

With two power sources and one load, only one circuit breaker can be closed

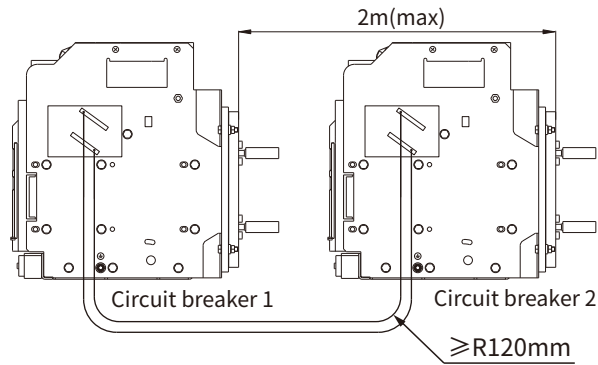
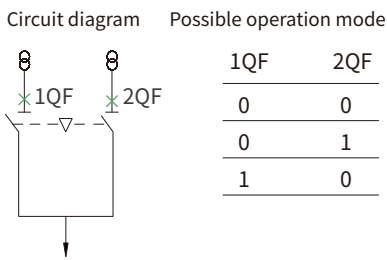

Steel cable interlocking or connecting rod interlocking of three circuit breaker

With three power sources and one load, only one circuit breaker can be closed

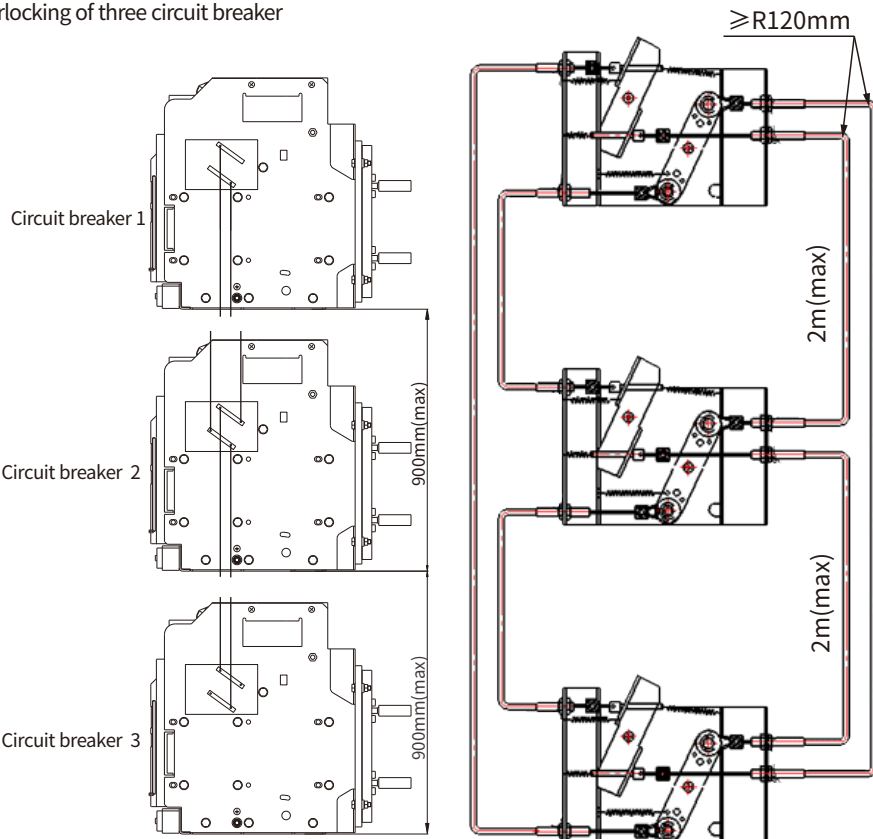
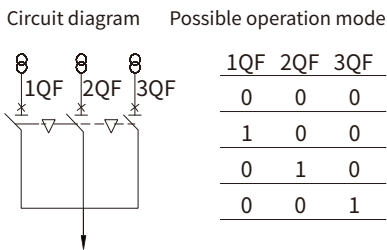

With two power sources and one load, a maximum of two circuit breakers can be closed

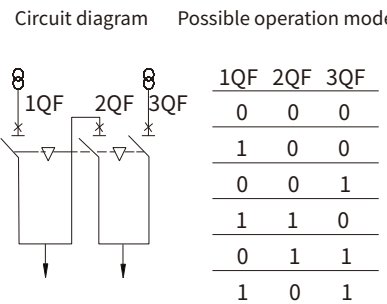

QF: Circuit breaker

Lever-three interlocking schematic diagram

Steel cable-three interlocking schematic diagram

Note 1: The transition arc at the steel cable interlock bending point is not less than R120mm;

Note 2: One circuit breaker can be removed from the lever-three interlocking scheme, which is now the lever-two interlocking scheme;

HUW9 Air Circuit Breaker

Functions and Features

Mechanical interlocking cutout positions and dimensions (applicable for circuit breakers mounting up to down)

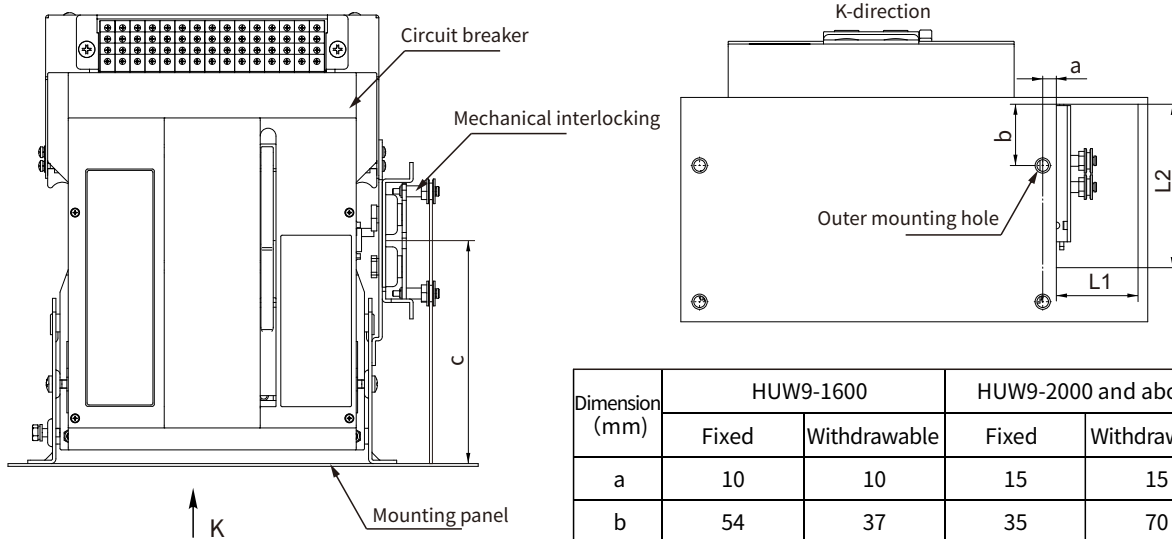

Dimension (mm)	HUW9-1600		HUW9-2000 and above	
	Fixed	Withdrawable	Fixed	Withdrawable
a	10	10	15	15
b	54	37	35	70
c	162.5	190	207	243
L1	60	60	75	75
L2	120	120	175	175

Circuit breaker maintenance

The purposes of circuit breaker maintenance are as follows:

- Monitor the operating status of the circuit breaker, to determine whether it is in the normal operating state;
- Predict and diagnose the potential faults and mal-functions of the circuit breaker and clear them;
- Beneficial for ensuring trouble-free operation of the circuit breaker during its life cycle.

The circuit breaker needs to be maintained under the following conditions

- Electrical faults due to insulation failure caused by remaining foreign matter or excessive dust;
- Operational faults and shorted life caused by jammed parts due to lack of maintenance on the circuit breaker's internal mechanism for long time, or lack of regular lubrication to the rotating and sliding parts;
- Control circuit failure, incorrect electrical signal feedback or failed electrical interlocking due to poor contact;
- During long time operation of the circuit breaker, relevant measures should be taken if the circuit breaker is affected by high temperature, humidity, pollution, vibration, and strong magnetic field interference, which can easily shorten the service life of the circuit breaker or cause it to malfunction;
- When the circuit breaker trips or an alarm accident occurs.

What is maintained on the circuit breaker?

Make sure to open the circuit breaker before conducting maintenance. For withdrawable circuit breakers, the basic device should be racked into the Disconnected position. Verify that the incoming and outgoing ends and the control circuit are not energized.

- Check whether there is dust, dirt, and water droplets on the circuit breaker. If any, please clean it with a dry cloth. In case of moisture, it is necessary to dry the device;
- Check whether the secondary wiring terminal's conductors are in good contact, and the screws are loosened or oxidized;
- Check whether the fixing screws are loosened or oxidized in the main circuit of the circuit breaker and the surface of the conductive copper bar is severely discolored. There should be no discoloration on the contact surface;
- Check with a 500V megger and make sure that the insulation resistance between the main circuit of each phase of the circuit breaker and between the disconnected incoming and outgoing wirings of the circuit breaker should not be less than 50MΩ;
- Manual charging, opening and closing of the circuit breaker are carried out normally and lead to no failure. And the withdrawable type circuit breakers can be racked in and out normally.
- Conduct regular maintenance on the circuit breaker (e.g. once every 6 months), for timely troubleshooting in case of any faults; Close and open the circuit breaker five times before putting into operation after maintenance, to ensure that the circuit breaker's contact system is in good contact

HUW9 Air Circuit Breaker

Functions and Features

Ordering instructions

Company:	Contact:	Phone:	Order Qty:	(units)	Order date:	
Product mode	<input type="checkbox"/> HUW9-1600	<input type="checkbox"/> HUW9-2000	<input type="checkbox"/> HUW9-2500	<input type="checkbox"/> HUW9-3200	<input type="checkbox"/> HUW9-4000 <input type="checkbox"/> HUW9-6300	
Rated current	<input type="checkbox"/> 200 <input type="checkbox"/> 400 <input type="checkbox"/> 630 <input type="checkbox"/> 800 <input type="checkbox"/> 1000 <input type="checkbox"/> 1250	<input type="checkbox"/> 630 <input type="checkbox"/> 800 <input type="checkbox"/> 1000 <input type="checkbox"/> 1250 <input type="checkbox"/> 1600 <input type="checkbox"/> 2000	<input type="checkbox"/> 2500	<input type="checkbox"/> 2000 <input type="checkbox"/> 2500 <input type="checkbox"/> 3200	<input type="checkbox"/> 4000 <input type="checkbox"/> 5000 <input type="checkbox"/> 6300	
No. of poles	<input type="checkbox"/> 3 P <input type="checkbox"/> 4 P					
Mounting method	<input type="checkbox"/> Fixed type <input type="checkbox"/> Withdrawable type					
Intelligent controller selection	Type	<input type="checkbox"/> 2M (Economy type) <input type="checkbox"/> 3M (Ordinary type) <input type="checkbox"/> 2H (smart type, digital display) <input type="checkbox"/> 3H (smart type, LCD display)				
	Rated voltage	<input type="checkbox"/> AC230V <input type="checkbox"/> AC400V <input type="checkbox"/> DC220V <input type="checkbox"/> DC110V <input type="checkbox"/> DC24V				
	Protection parameter setting	Factory default settings: Ir=1In, Tr=15s; fixed time Isd=8Ir, Tsd=0.4s; inverse time Is= 4Ir; li=12In; Ig is OFF {default value Ig=In, inverse time shear coefficient k = OFF, Tg=0.4s}				
		Long delay protection Ir	Ir= In (select a value from 0.4 to 1.0, or OFF) Tr(1.5Ir) = s (select a value from 15, 30, 60, …, 960)			
		Short-circuit short-time delay protection Isd	Isd= Ir (select a value from 1.5 to 15, or OFF) <input type="checkbox"/> Fixed time Tsd = s (select a value from 0.1 to 0.4);			
Short-circuit instantaneous protection li		li= In(select a value from 1.0 to 20, or OFF) , , with the maximum of 100kA				
Optional function	Ground protection Ig	Ig= In (select a value from 0.2 to 1.0, or OFF) Tg= s (select a value from 0.1 to 1.0) Inverse time shear coefficient k= (select a value from 1.5 to 6, or OFF)				
	<input type="checkbox"/> Voltage measurement <input type="checkbox"/> Frequency measurement <input type="checkbox"/> Voltage unbalance rate measurement <input type="checkbox"/> Phase sequence detection <input type="checkbox"/> Power measurement <input type="checkbox"/> Power factor measurement <input type="checkbox"/> Temperature control monitoring <input type="checkbox"/> Electric energy measurement <input type="checkbox"/> Zone interlock (ZSI) function <input type="checkbox"/> Harmonics measurement <input type="checkbox"/> Overvoltage protection <input type="checkbox"/> Undervoltage protection <input type="checkbox"/> Voltage unbalance protection <input type="checkbox"/> Over frequency protection <input type="checkbox"/> Under frequency protection <input type="checkbox"/> Phase sequence protection <input type="checkbox"/> Reverse power protection <input type="checkbox"/> Demand protection <input type="checkbox"/> Demand measurement (current, power) <input type="checkbox"/> Residual operating current protection <input type="checkbox"/> Load monitoring function <input type="checkbox"/> Neutral line protection <input type="checkbox"/> DI input function <input type="checkbox"/> DO output function <input type="checkbox"/> Communication function: Modbus protocol (Mic5.0 standard configuration) <input type="checkbox"/> Internet of things function (wifi, GPRS)					
Accessories equipped as standard	Closing electromagnet	<input type="checkbox"/> AC230V <input type="checkbox"/> AC400V <input type="checkbox"/> DC220V <input type="checkbox"/> DC110V				
	Shunt release	<input type="checkbox"/> AC230V <input type="checkbox"/> AC400V <input type="checkbox"/> DC220V <input type="checkbox"/> DC110V				
	Charging motor	<input type="checkbox"/> AC230V <input type="checkbox"/> AC400V <input type="checkbox"/> DC220V <input type="checkbox"/> DC110V				
	Auxiliary switch	<input type="checkbox"/> Changeover 4NO/4NC <input type="checkbox"/> Independent 4NO/4NC <input type="checkbox"/> Changeover 6NO/6NC <input type="checkbox"/> Independent 6NO/6NC <input type="checkbox"/> Special type (Note: HUW9-1600 device can be equipped with Changeover 4NO/4NC or Changeover 6NO/6NC)				
	Escutcheon + sealing ring	Fixed type <input type="checkbox"/> Withdrawable type				
Optional accessories	Undervoltage release	<input type="checkbox"/> Self-drawn		<input type="checkbox"/> Assisted drawn (by default)		
		<input type="checkbox"/> AC230V <input type="checkbox"/> AC400V				
	Key lock	<input type="checkbox"/> Self-drawn <input type="checkbox"/> 0.5s <input type="checkbox"/> 1s <input type="checkbox"/> 3s <input type="checkbox"/> 5s		<input type="checkbox"/> Assisted drawn (by default)		
		<input type="checkbox"/> One circuit breaker with one lock and one key <input type="checkbox"/> Two circuit breakers with two locks and one key <input type="checkbox"/> Three circuit breakers with three locks and two keys <input type="checkbox"/> Special form (customized according to user requirements)				
	Mechanical interlocking	<input type="checkbox"/> Two circuit breakers <input type="checkbox"/> Lever interlocking (up-down interlocking) <input type="checkbox"/> Steel cable interlocking				
Dual-power controller	<input type="checkbox"/> Leakage current transformer <input type="checkbox"/> N-phase current transformer <input type="checkbox"/> Ground current transformer <input type="checkbox"/> Power adapter <input type="checkbox"/> Door interlocking <input type="checkbox"/> Relay module <input type="checkbox"/> Protocol conversion module (Profibus-DP, Device Net) <input type="checkbox"/> Cassette electrical three-position lock <input type="checkbox"/> Charging-ready electrical indication <input type="checkbox"/> Opening/closing button lock <input type="checkbox"/> Secondary wiring terminal cover <input type="checkbox"/> Counter					
Others	<input type="checkbox"/> Leakage current transformer <input type="checkbox"/> N-phase current transformer <input type="checkbox"/> Ground current transformer <input type="checkbox"/> Power adapter <input type="checkbox"/> Door interlocking <input type="checkbox"/> Relay module <input type="checkbox"/> Protocol conversion module (Profibus-DP, Device Net) <input type="checkbox"/> Cassette electrical three-position lock <input type="checkbox"/> Charging-ready electrical indication <input type="checkbox"/> Opening/closing button lock <input type="checkbox"/> Secondary wiring terminal cover <input type="checkbox"/> Counter					

Note 1: Please consult with the manufacturer before ordering if any special requirements

Note 2: The costs for optional functions and accessories of the circuit breaker are not included in the standard configuration of the circuit breaker, which should be calculated separately.

Note 3: A mechanical interlock must be selected as well when a dual-power controller is selected.



Unlock More: Scan Now

HUANYU HIGH-TECH CO.,LTD.

ADD:Wenzhou Bridge Industrial Zone,Yueqing,Zhejiang,China.

WhatsApp/MOB:0086-135 0655 2522

Email:austin@huyu.com.cn

www.huyuelectric.com

Version number:HUYU202503 (Due to the continuous updating of product technology, all data should be based on the latest confirmation of the company's technical departments.)